

Helical Feed Antennas

Paul Wade W1GHZ ©2002

w1ghz@arrl.net

Helical antennas have long been popular in applications from VHF to microwaves requiring circular polarization, since they have the unique property of naturally providing circularly polarized radiation. One area that takes advantage of this property is satellite communications. Where more gain is required than can be provided by a helical antenna alone, a helical antenna can also be used as a feed for a parabolic dish for higher gains. As we shall see, the helical antenna can be an excellent feed for a dish, with the advantage of circular polarization. One limitation is that the usefulness of the circular polarization is limited since it cannot be easily reversed to the other sense, left-handed to right-handed or vice-versa.

Helical Antennas

John Kraus, W8JK, is the originator of the helical-beam antenna; as he puts it¹, “which I devised in 1946”. His 1950 book, *Antennas*², is the classic source of information. The recent third edition³, *Antennas for All Applications*, has significant additional information.

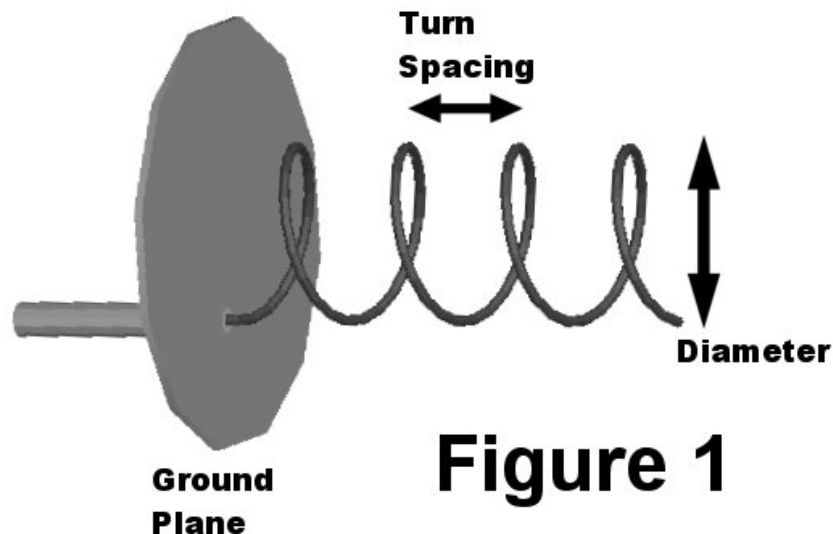

A sketch of a typical helical antenna is shown in Figure 1. The radiating element is a helix of wire, driven at one end and radiating along the axis of the helix. A ground plane at the driven end makes the radiation unidirectional from the far (open) end. There are also configurations that

radiate perpendicular to the axis, with an omnidirectional pattern. The familiar “rubber ducky” uses this configuration; we all know that it is a relatively poor antenna, so we shall only consider the axial-mode configuration.

Typical helix dimensions for an axial-mode helical antenna have a helix circumference of one wavelength at the center frequency, with a helix pitch of 12 to 14 degrees. Kraus defines the pitch angle α as:

$$\alpha = \tan^{-1} \frac{S}{\pi D}$$

where s is the spacing from turn to turn and D is the diameter, the circumference divided by π . The triangle below illustrates the relationships between the circumference, diameter, pitch, turn spacing, and wire length for each turn:

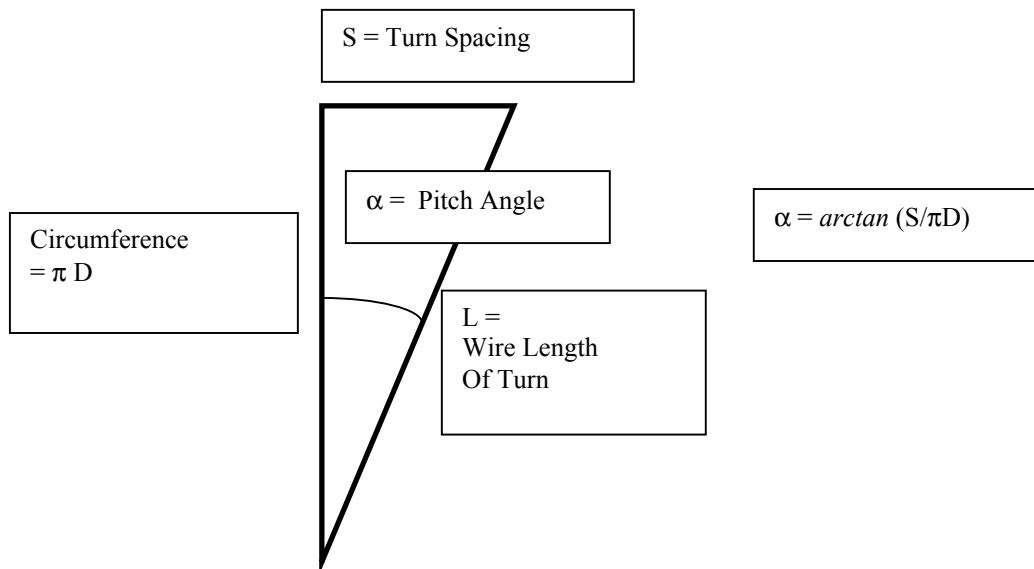

The ground plane diameter is typically 0.94λ in diameter at the center frequency, but many other configurations have been used, including square plates, wire grids, cavities, and loops¹. The 3 dB beamwidth for a helix with n turns is approximately²:

$$BW_{3dB} = \frac{52}{C_\lambda \sqrt{n \cdot s_\lambda}} \text{ degrees, where the circumference, } C_\lambda, \text{ and the turn}$$

spacing, s_λ , are in wavelengths.

The gain of the helical antenna is also proportional to the number of turns. The gain curves in Kraus' 1950 book², and many others, show the gain increasing with helix length with no apparent limit. However, experiments with long helical antennas are invariably disappointing. Darrel Emerson, AA7FV, made a series of NEC2 simulations of various length helical antennas and showed^{4,5} that the gain approaches a limit of about 15 dB, for a length of around 7 wavelengths. The 2002 Kraus book³ shows similar experimental data. For higher gains, arrays of multiple helices are needed, or other types of antennas.

Almost all helical antennas have been made with uniform diameter and turn spacing. K2RIW once suggested that long helical antennas might require variations in diameter and spacing over the length of the antenna, just as optimized long Yagi-Uda antennas require variable element lengths and spacings for very high gain.

Some of the AMSAT satellites and others require more than 15 dB gain with circular polarization for good reception. Until someone finds an optimization that yields higher gain from a long helix, some other antenna type is needed; a parabolic dish is often a good choice. While a large dish can provide gains upward of 30 dB, a small dish can easily provide the 20 to 25 dB gain needed for many satellite applications. The beamwidth of a small dish is broader than the beam of a large dish, making tracking less difficult. Of course, the dish needs a feed antenna, and a short helix is a good choice for circular polarization. A small offset dish is very attractive, since the feed blockage, which degrades small dish performance, is greatly reduced.

Helical antennas are relatively broadband, typically useful over a range of frequencies relative to the helix circumference of $3/4\lambda$ to $4/3\lambda$, or roughly a 60% bandwidth. Most of the microwave ham bands are spaced by about this much, so there might be the possibility of covering two bands with one helical antenna, one band at the lower limit of the antenna bandwidth and the other at the upper limit. However, we shall see that for a feed antenna, the radiation patterns are much more useful near the center of the range. Thus, the main advantage of the broadband characteristic of the helical antenna is that the dimensions are not critical.

Helix Feed 4 turns 12.5° with 0.94λ GP diameter at 2.4 GHz

Figure 2

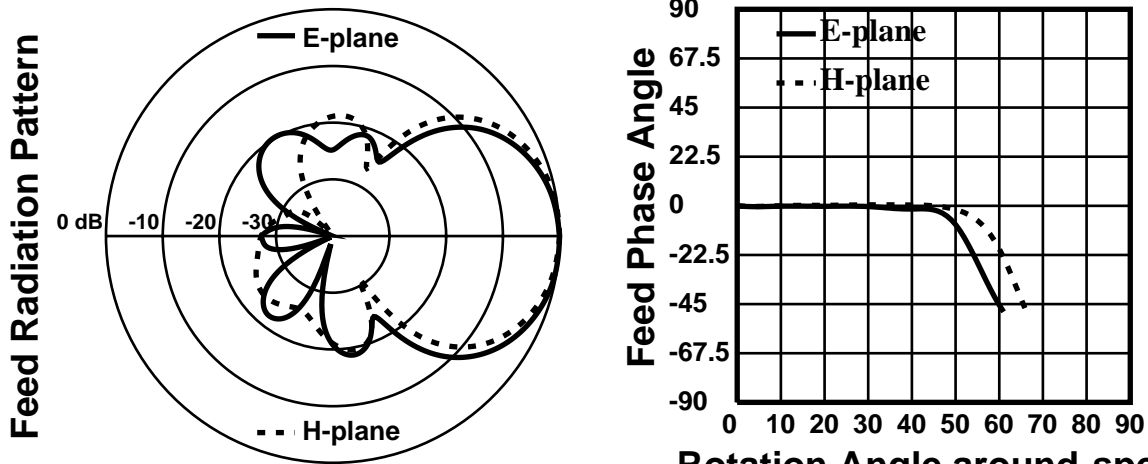

Dish diameter = 10 λ Feed diameter = 0.94 λ

Rotation Angle around specified Phase Center = 0.21 λ in front of GP

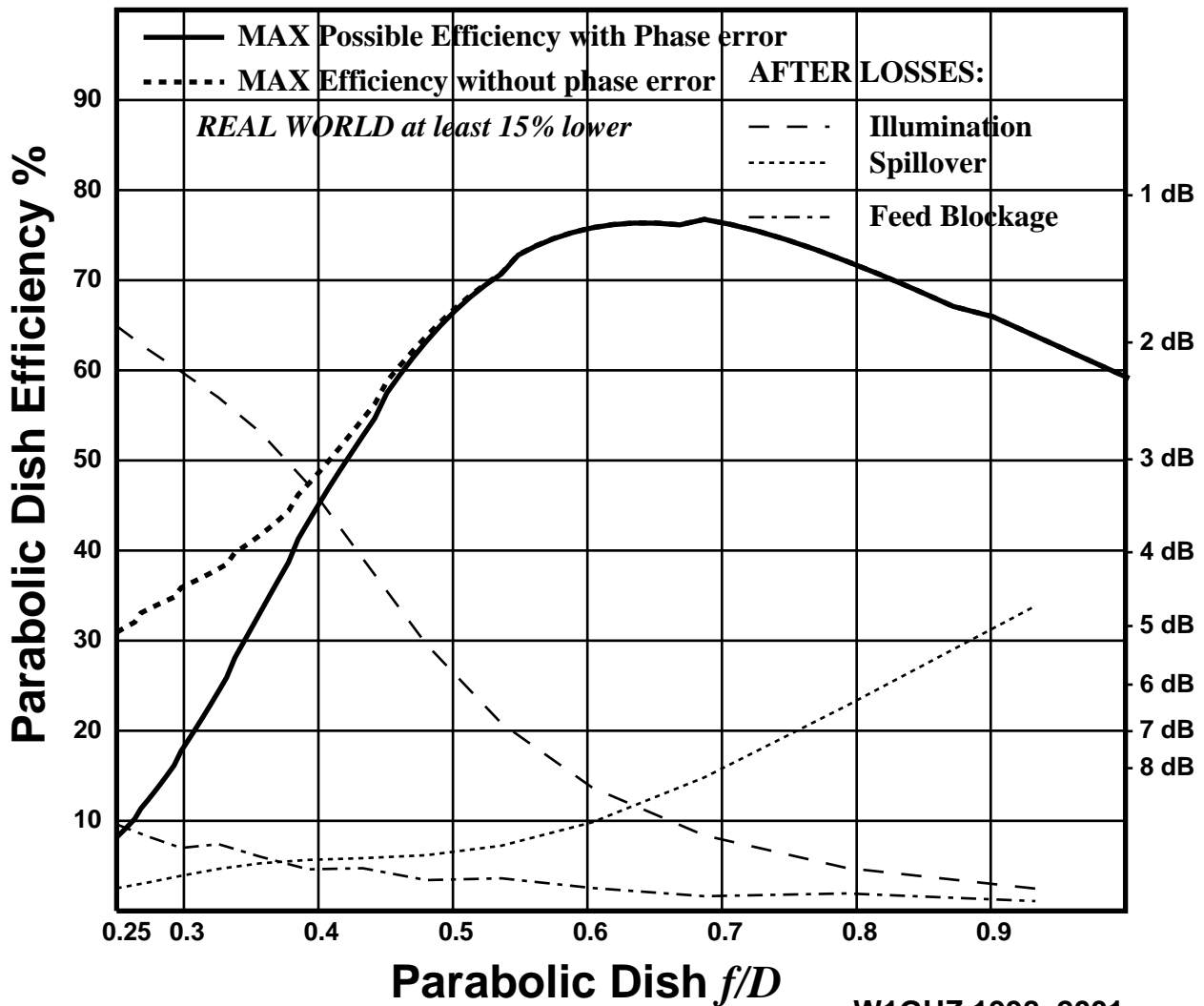

Helical feed antennas

A parabolic dish reflector typically requires a feed antenna with a rather large beamwidth, 90° or more. From the beamwidth formula above, only a short helix of a few turns is needed. Figure 2 shows the radiation pattern provided by a typical short helix, 4 turns with a 12.5° pitch and a ground plane of 0.94λ diameter. The calculated dish efficiency with this helix as a feed is very good, about 77%, at a center frequency of 2.4 GHz, with best f/D around 0.69, just about right for an offset-fed dish. Thus, we might expect a real efficiency $>60\%$ feeding a reasonably sized ($>10\lambda$) offset dish. A three-dimensional view of the radiation pattern, in Figure 3, shows a reasonably clean pattern with relatively small sidelobes; adjacent shades of gray have a difference in amplitude of 2 dB. The backlobes of most helical antennas, like the one in Figure 3, seem to have a twisted asymmetric shape.

4 Turn Helix at 2.4 GHz

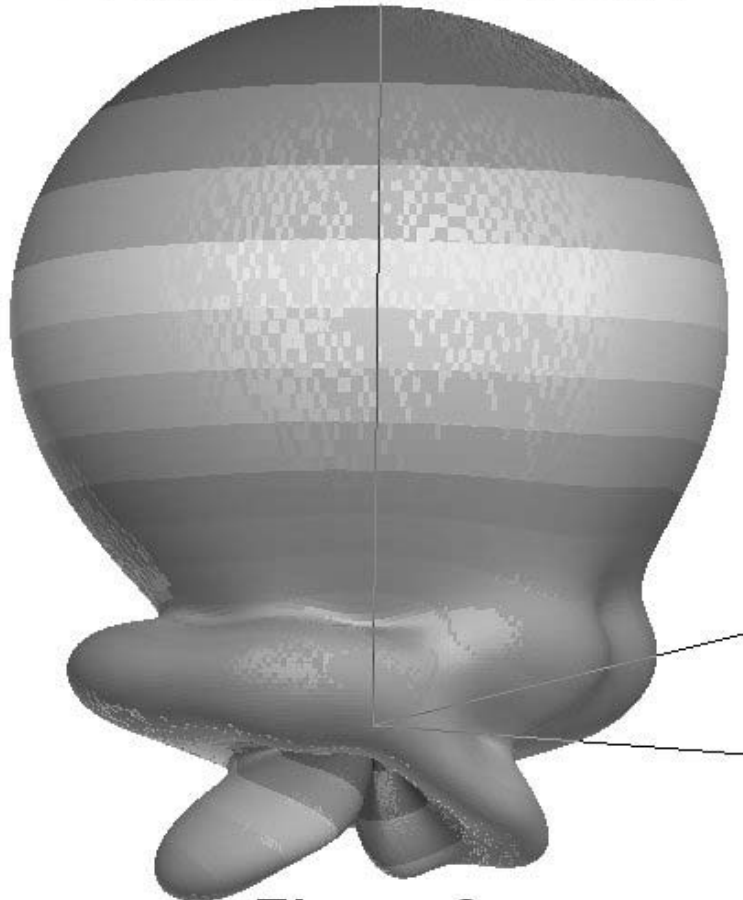
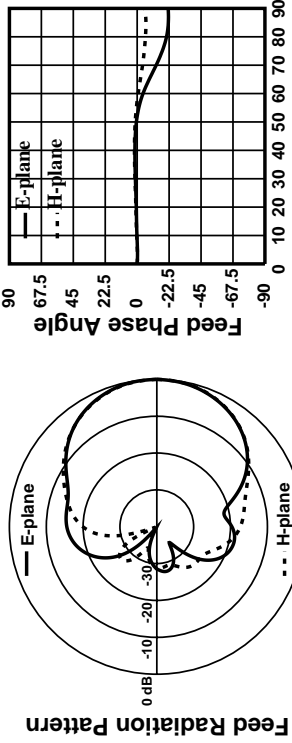

Figure 3

Helix 4 turns 12.5°, 0.94λ GP, at 1.8 GHz

Figure 4a



Dish diameter = 10 λ. Feed diameter = 0.94 λ. Rotation Angle around specified Phase Center = 0.04 λ in front of GP

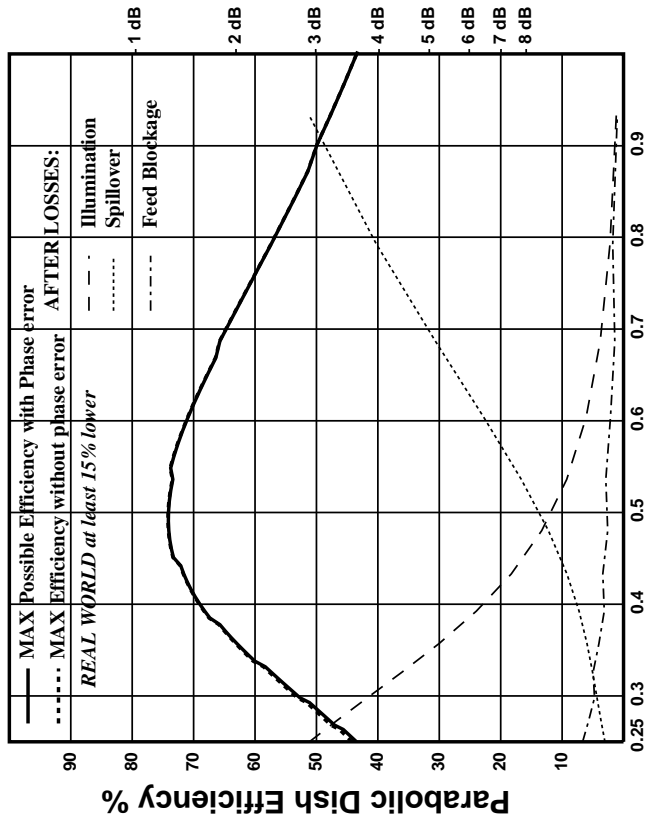

Parabolic Dish f/D

W1GHZ 1998, 2001

Helix 4 turn 12.5°, 0.94λ GP, at 2.0 GHz

Figure 4b

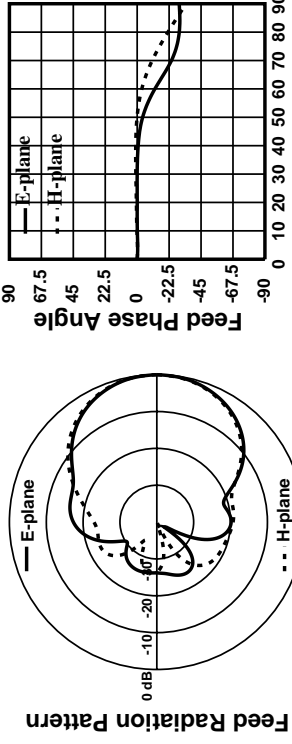

Dish diameter = 10 λ. Feed diameter = 0.94 λ. Rotation Angle around specified Phase Center = 0.08 λ in front of GP

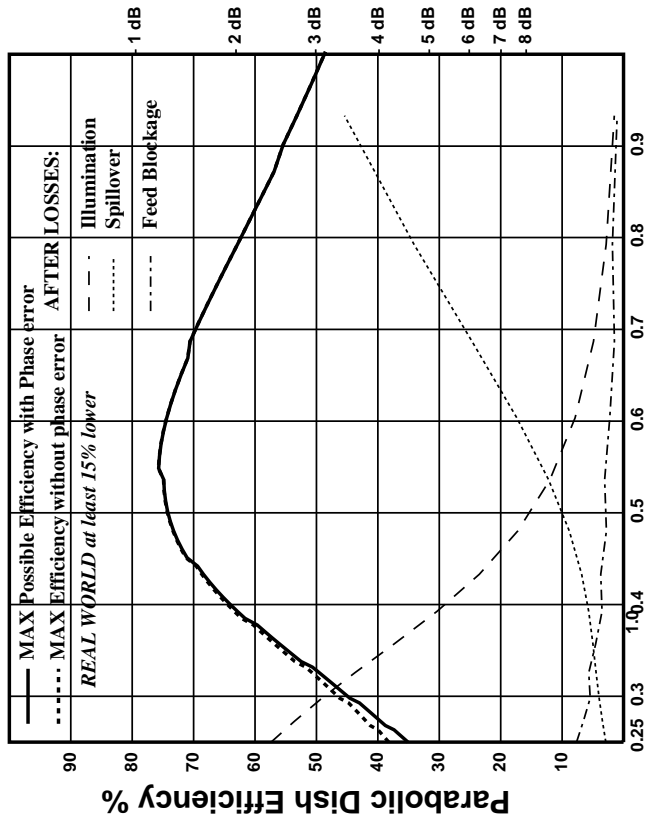

Parabolic Dish f/D

W1GHZ 1998, 2001

Helix 4 turns 12.5°, 0.94λ GP, at 2.2 GHz

Figure 4c

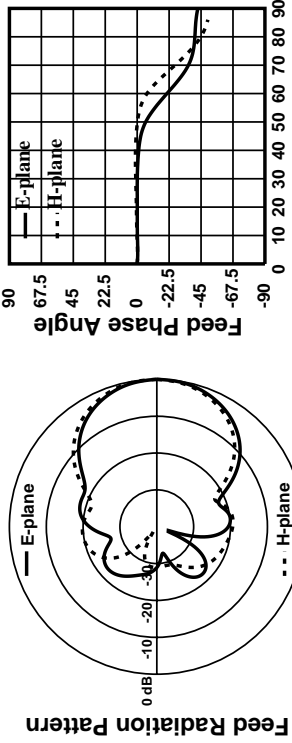

Dish diameter = 10 λ. Feed diameter = 0.94 λ. Rotation Angle around specified Phase Center = 0.12 λ in front of GP

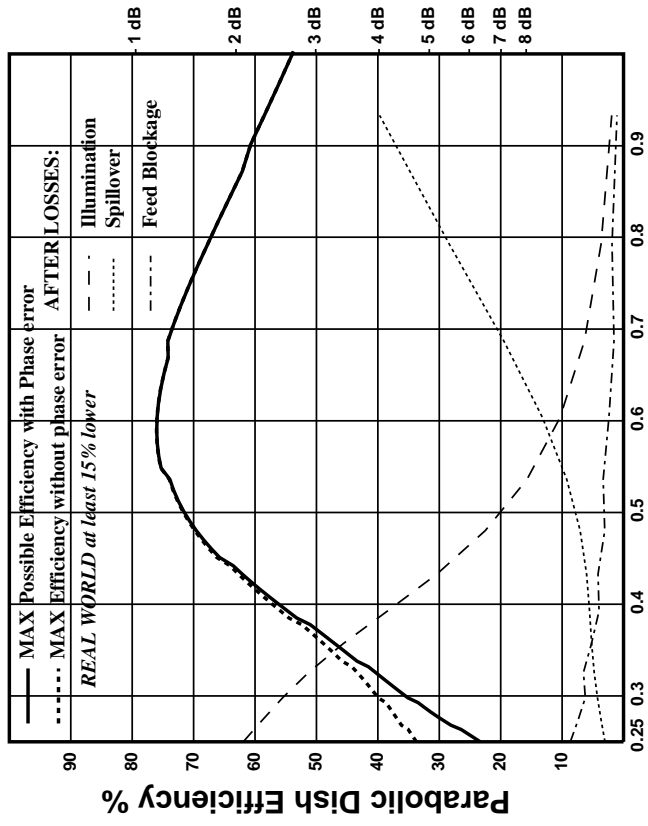

Parabolic Dish f/D

W1GHz 1998, 2001

Helix 4 turns 12.5°, 0.94λ GP, at 2.6 GHz

Figure 4d

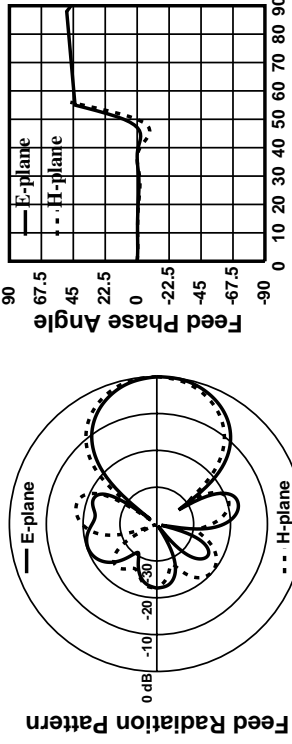

Dish diameter = 10 λ. Feed diameter = 0.94 λ. Rotation Angle around specified Phase Center = 0.40 λ in front of GP

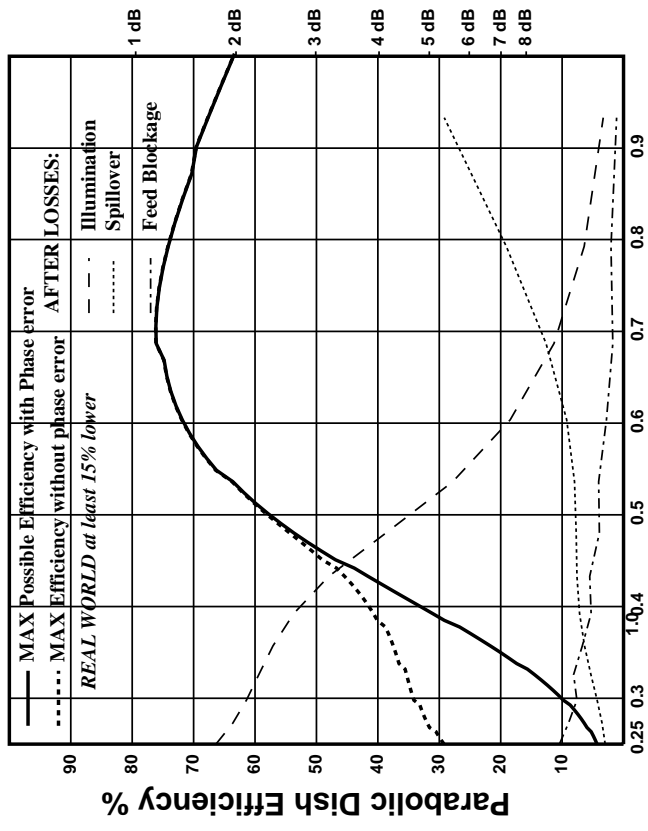

Parabolic Dish f/D

W1GHz 1998, 2001

Helix 4 turns 12.5°, 0.94λ GP, at 2.8 GHz

Figure 4e

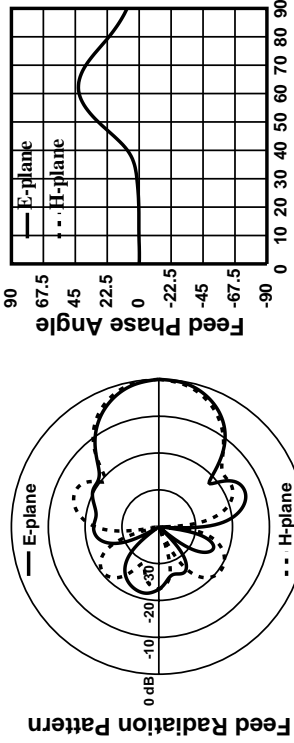

Dish diameter = 10 λ. Feed diameter = 0.94 λ.

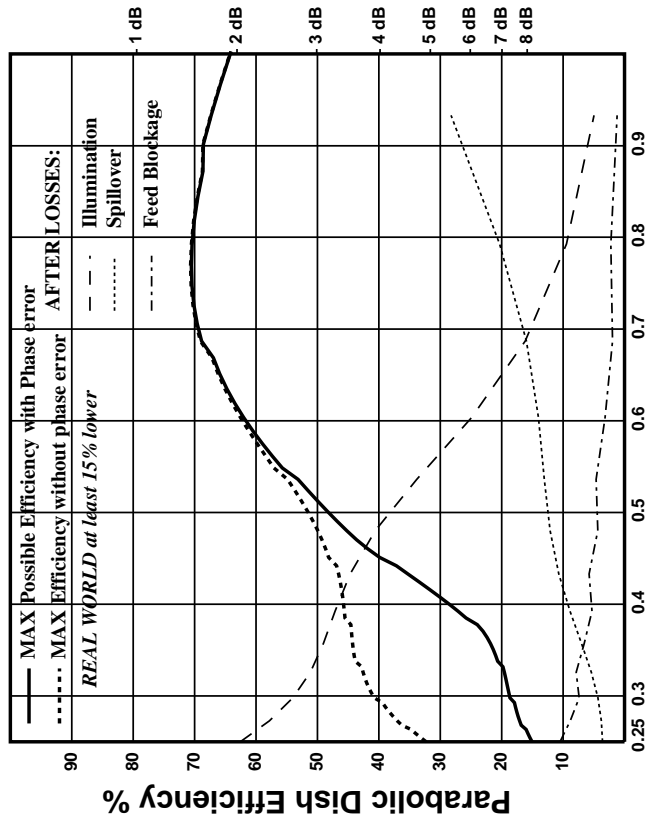

W1GHZ 1998, 2001

Parabolic Dish f/D

Helix 4 turns 12.5°, 0.94λ GP, at 3.0 GHz

Figure 4f

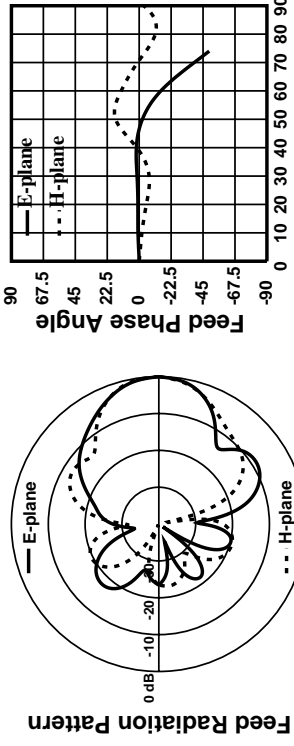

Dish diameter = 10 λ. Feed diameter = 0.94 λ.

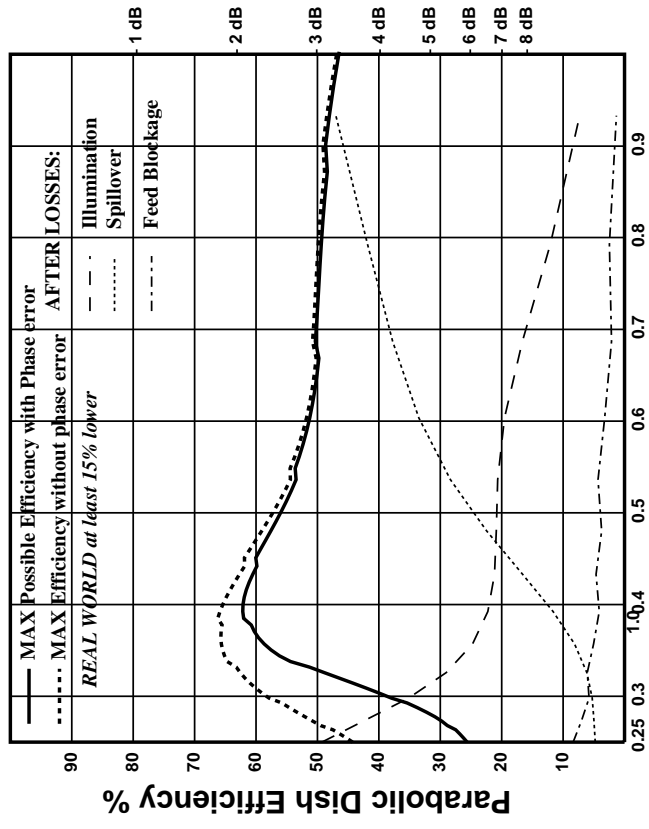

W1GHZ 1998, 2001

Parabolic Dish f/D

The bandwidth of the helical feed can be seen from calculated radiation patterns over a 50% bandwidth, from 1.8 to 3.0 GHz, shown in Figure 4.

Figure 5: Helix feed - 4 turns, 12.5 deg, 0.94 lambda GP

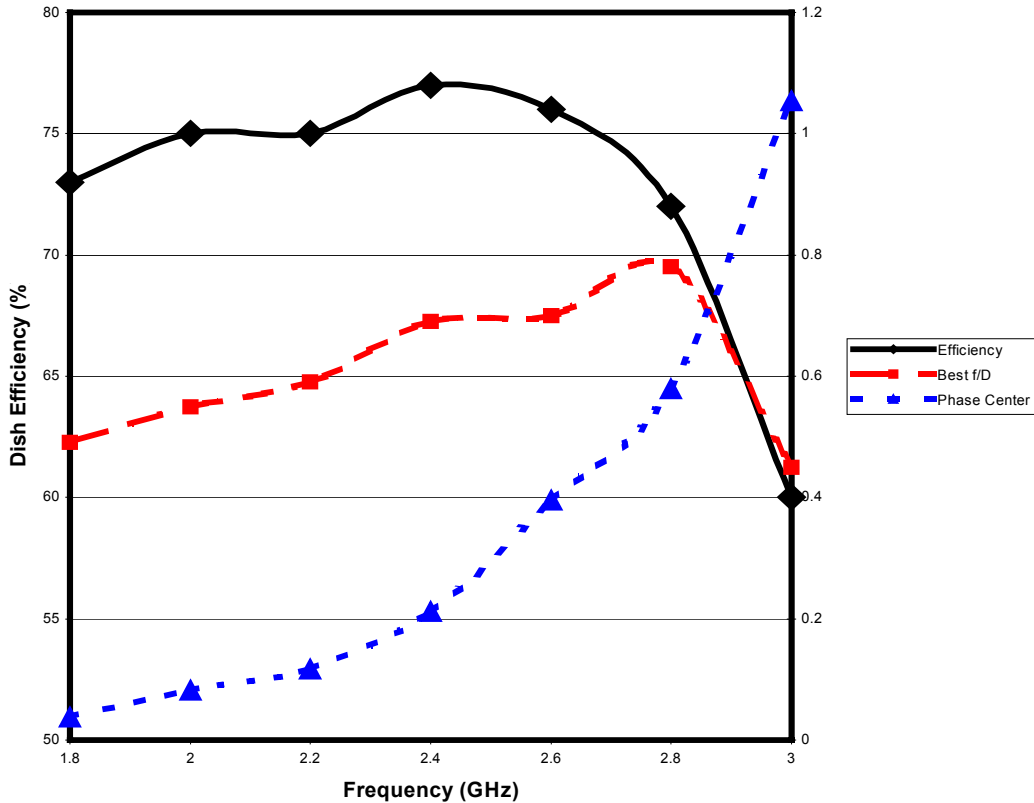

The calculated efficiency remains high from 2.0 to 2.6 GHz, about a 25% bandwidth. At the ends of the range, the efficiency falls off and the patterns deteriorate, with higher sidelobe levels, particularly at the higher-frequency end. Best f/D also varies with frequency. Figure 5 is a graph of efficiency and best f/D vs. frequency. Phase center is also plotted – it is reasonable constant over the lower half of the frequency range, but moves rapidly at the higher end of the range. We can conclude that this helical feed would work well on a single band, but would not provide good performance on any two adjacent ham bands.

The radiation patterns in Figures 2,3, and 4 were calculated using a 3D program; I have used both Zeland **Fidelity**⁶ and Ansoft **HFSS**⁷ programs to calculate helical antenna patterns. While both programs are quite expensive, the free **NEC2**⁸ program will also do an excellent job on helical antennas; it simply lacks the graphical input and output capabilities. All the patterns in

this paper are calculated, but many hams have reported good experimental results with helical feeds, so we have some assurance of validity.

Since my first helical feed calculations were so promising, I ran calculations over a range of dimensions to see if there are optimum combinations. By a serendipitous accident, I found that helix pitches much smaller than the recommended optimum pitch of 12 to 14 degrees seemed to work well, so I expanded the range to include pitches from 7.5 to 15 degrees and lengths from 2 to 5 turns. The helix dimensions were targeted for a center frequency of 2.4 GHz, and patterns calculated over 1.8 to 3.0 GHz.

The results, rather than finding any optimum, suggest that the helical antenna is a very forgiving feed – near the center design frequency, almost any dimensions will work to some degree. Figure 6 plots the efficiency,

Figure 6: Helix Feeds at 2.4 GHz

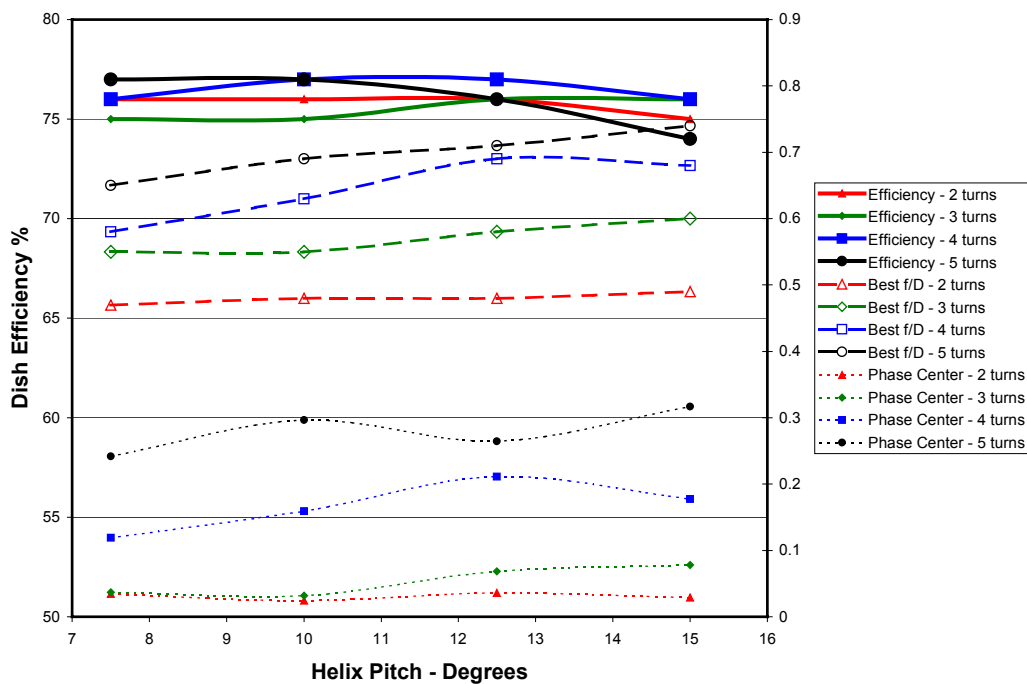

optimum f/D , and phase center at the center frequency for all of the helical feeds, and all are very good. Only the optimum f/D , varies; as expected, the narrower beamwidth of a longer helix provides the narrower illumination angle needed for a larger f/D . None of the combinations showed a significantly larger bandwidth than Figure 5.

Since all the helical feeds are good, the design procedure is simple: pick a combination that is best for the f/D of your dish, and wind the helix. Then put the phase center of the feed at the focus of the dish. Figure 6 plots the phase center for all combinations at the center frequency. All are just in front of the ground plane, with the larger pitches a bit farther out. Since an offset-fed dish is more forgiving of phase-center error, placing the ground plane at the focus should be close enough. (For the finicky: the wire diameter for all calculations was 3 mm, and the helix started 4 mm in front of the ground plane, so that the beginning of the first turn was clear of the ground plane.)

Ground Plane variations

All of the variations of helix length and pitch shown in Figure 6 had a constant ground plane (GP) size, 118 mm, or 0.94λ diameter at the center frequency. Varying this diameter by $\pm 20\%$, so that the diameter is 0.94λ at the highest or lowest frequency, had little effect, as shown in Figure 7.

Figure 7: Helix feed (4t 12.5deg) with varying GP

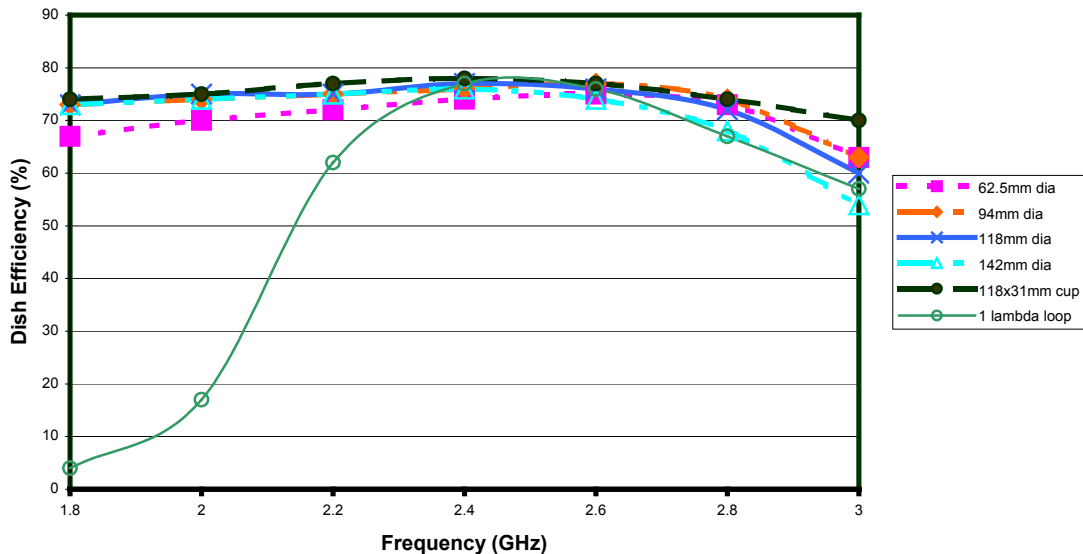

Reducing the diameter to 0.5λ lowered the efficiency slightly, while a cavity groundplane 0.94λ in diameter and $\lambda/4$ deep increased it slightly. The phase center and optimum f/D show only small variations near the center frequency. The only significant difference was found when the ground plane is replaced by a loop¹ 1λ in circumference, with a second loop behind it. The loop still provides high dish efficiency near the center frequency, but the bandwidth is much narrower, $\sim 20\%$.

K5OE 2.4 GHz helix 5 turns, 13.43°, 100x50mm cavity GP

Figure 8

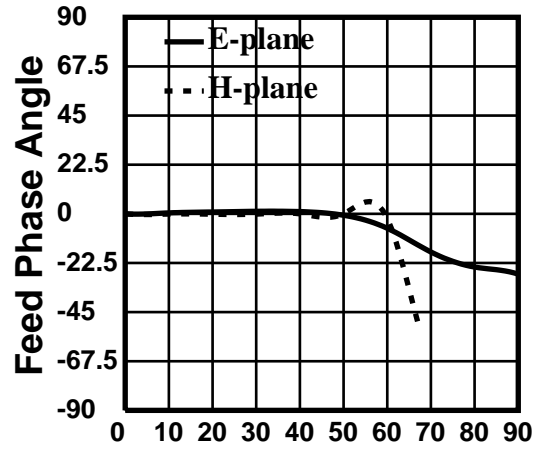
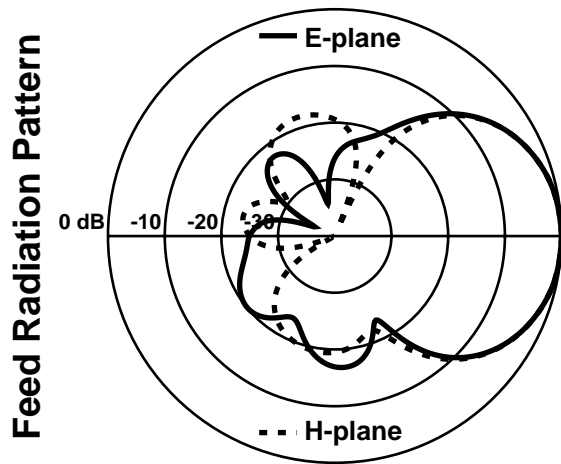

Dish diameter = 10λ Feed diameter = 0.8λ

Rotation Angle around specified
Phase Center = 0.6λ in front of GP

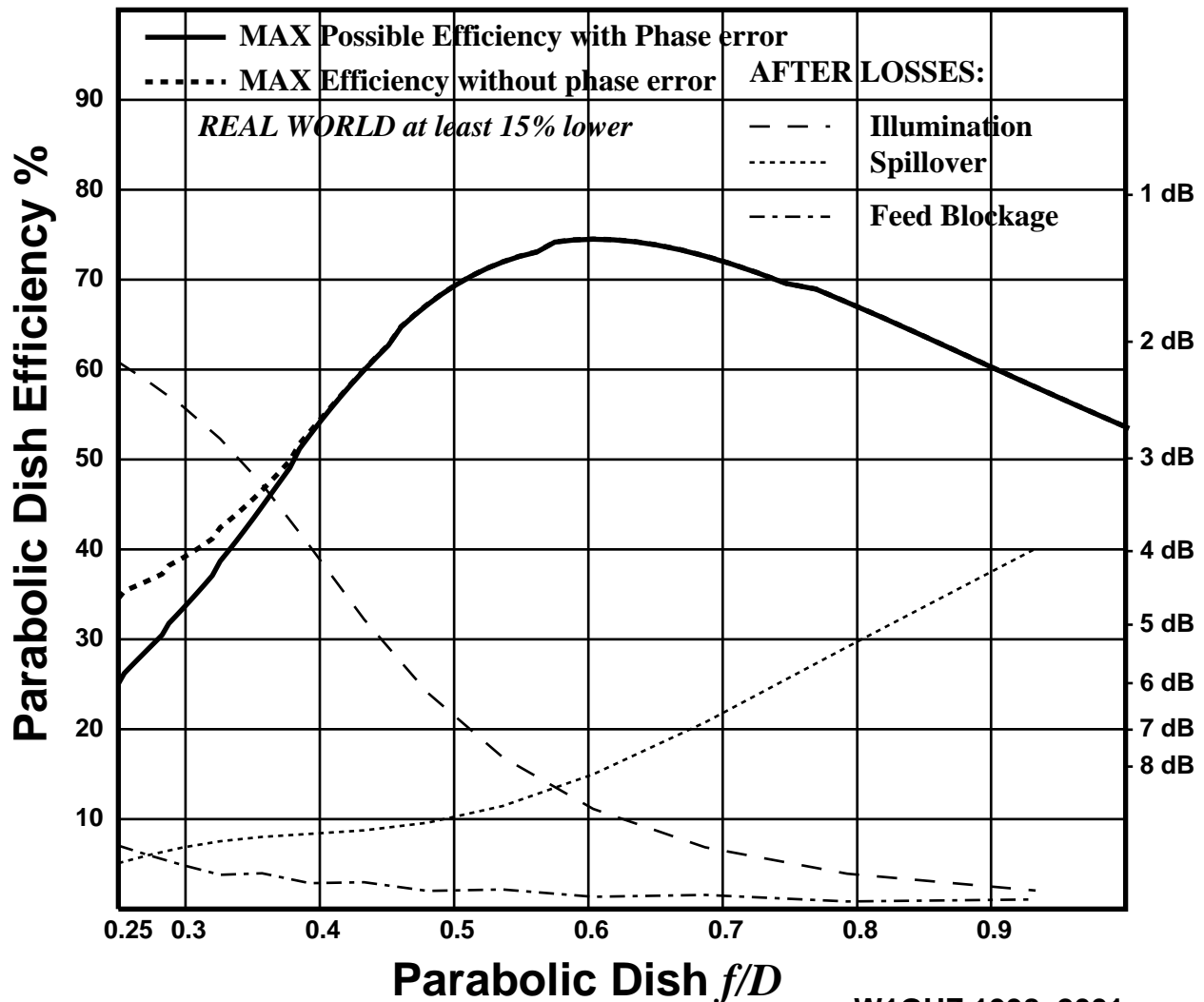

The cavity groundplane was suggested by K5OE, who used the dimensions suggested by Kraus³: 0.75λ diameter and 0.375λ deep, on a 5 turn helix with a pitch of 13.43° . This calculated patterns and efficiency curves for this helical antenna are shown in Figure 8. Efficiency is very good, but the bandwidth, shown in Figure 9, is narrower than with a flat ground plane.

Figure 9: K5OE 5-turn 13.4 degree Helix Feed - Efficiency

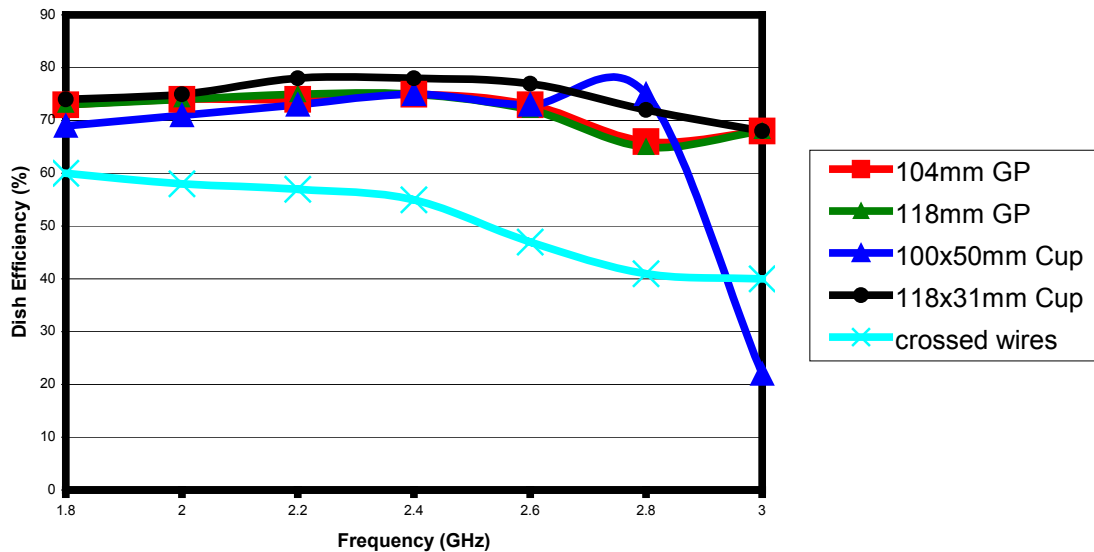

I tried some ground plane variations with this helix also. One was a larger, shallower cavity, 0.94λ in diameter and $\lambda/4$ deep. This provided slightly higher efficiency with much better bandwidth, as shown in Figure 9, and in the pattern and efficiency curves, Figure 10. Both cavity ground planes were slightly better than flat ones of the same diameter, also shown in Figure 9. The cavity ground planes reduce side and back lobes so that the efficiency is increased slightly, but the optimum f/D decrease – the effective length of the helix is only the part outside of the cavity. To feed an offset dish with a cavity-GP helix, we must increase the length to compensate – in this case, from about 4 turns to 6 turns with the deeper cavity or 5 turns with the shallower one. Figure 11 shows the radiation pattern and high efficiency of these two helix feed antennas.

A final ground plane experiment was a simple crossed wires 0.94λ long, like the reflector on a crossed Yagi-Uda antenna. The efficiency curve for the crossed-wire GP is significantly lower than the others in Figure 9.

Helix 5 turns 13.43°, 118x31mm cavity GP, at 2.4 GHz

Figure 10

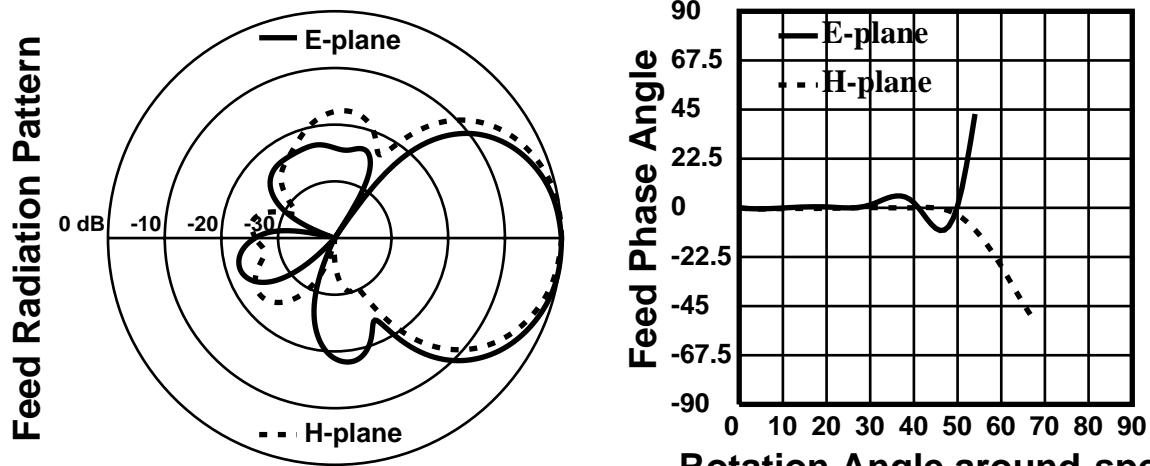

Dish diameter = 10λ Feed diameter = 0.94λ

Rotation Angle around specified Phase Center = 0.41λ in front of GP

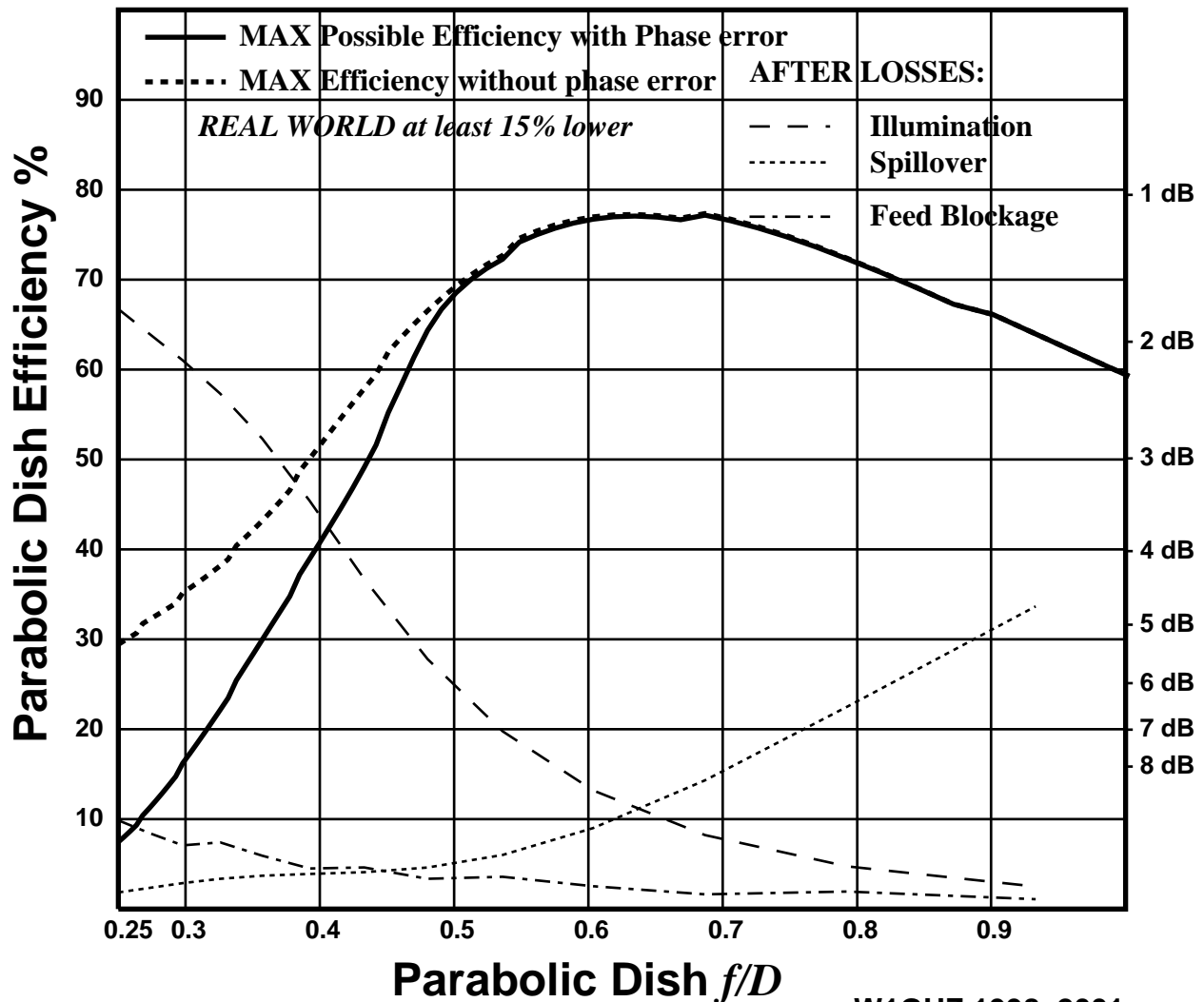

K50E helix 6 turns, 13.43°, 100x50mm cavity GP at 2.4 GHz

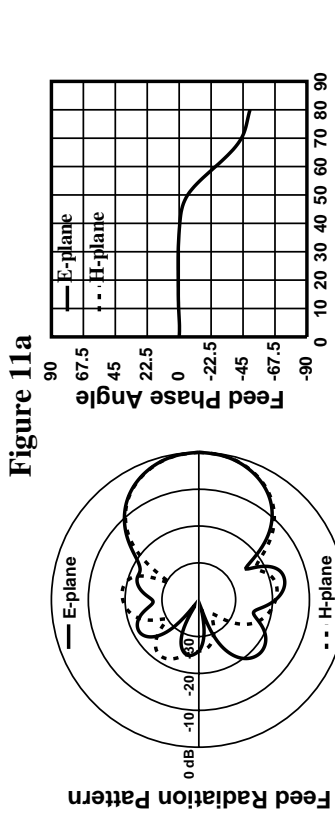

Rotation Angle around specified Phase Center = 0.68 λ in front of GP
Dish diameter = 10 λ . Feed diameter = 0.94 λ .

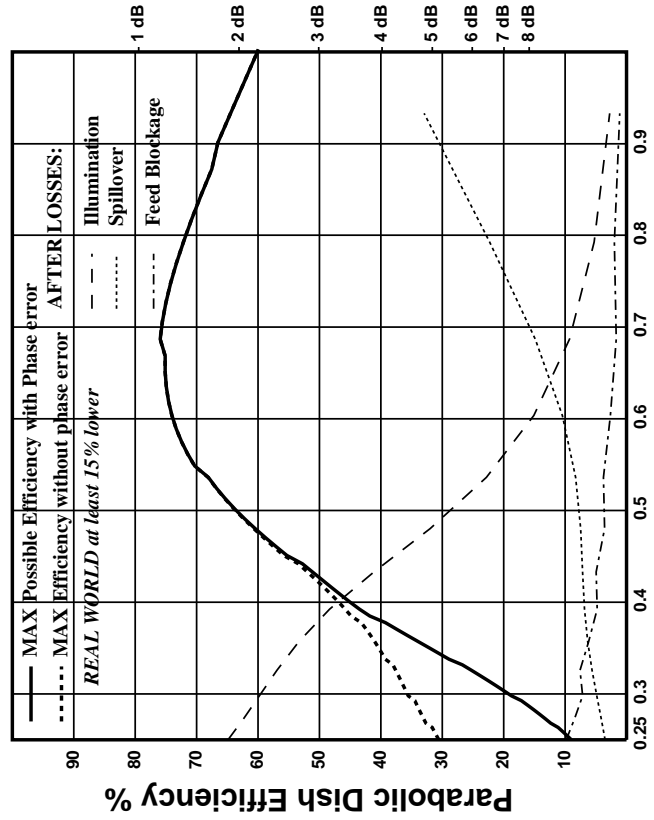

Parabolic Dish f/D W1GHZ 1998, 2002

K50E helix 6 turns, 13.43°, 118x31mm cavity GP at 2.4 GHz

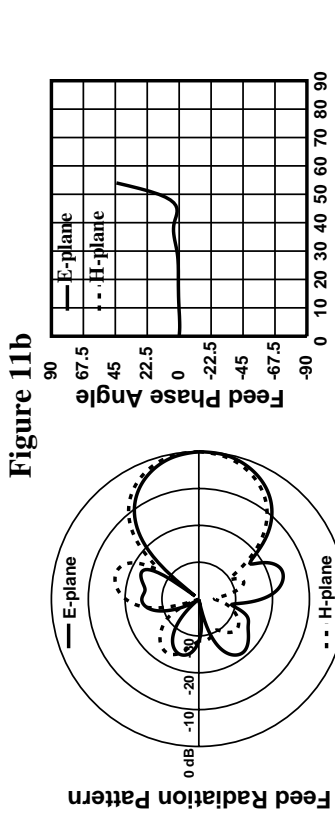

Rotation Angle around specified Phase Center = 0.57 λ in front of GP
Dish diameter = 10 λ . Feed diameter = 0.94 λ .

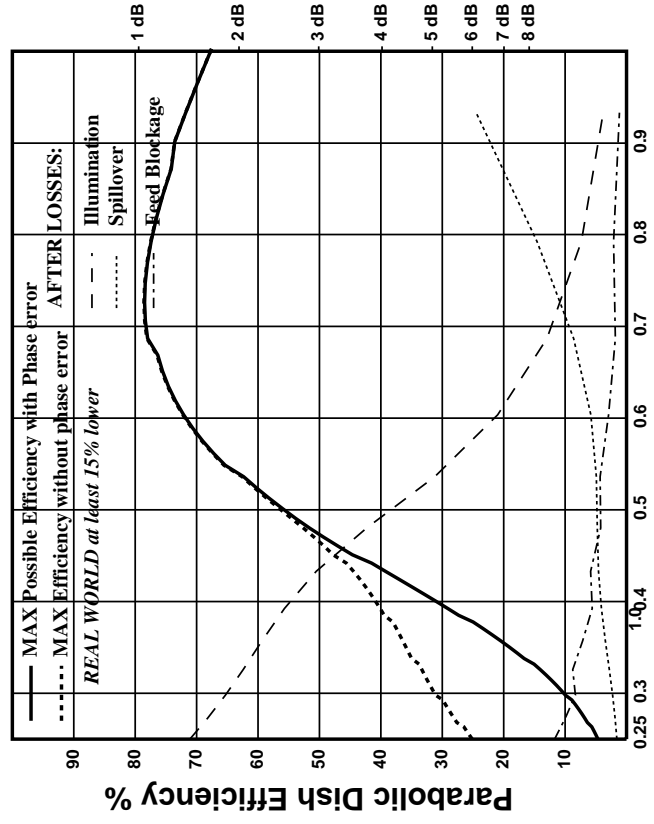

Parabolic Dish f/D W1GHZ 1998, 2002

Deep dishes

All the calculated helical feeds are only suitable for shallow dishes or offset-fed dishes, with $f/D > 0.5$, while most prime-focus dishes are deeper, with $f/D = 0.4$ or smaller. For shallow dishes, a different form of helix is needed. One possibility is a backfire helix⁹, with a small loop instead of a ground plane – the loop is smaller in diameter than the helix diameter, like a director on a loop-Yagi. The radiation peak is toward the end with loop, and the beam is broader than a helix with ground plane. Figure 12 is the radiation pattern and calculated efficiency for a 7-turn helix with 14° pitch, with a loop 0.29λ in diameter. Calculated efficiency is 80% for an $f/D = 0.33$. Efficiency remains high at other frequencies, while best f/D decreases with increasing frequency, as shown in Figure 13. Thus, it might be possible to match the reflector f/D by dimensioning the helix for a different center frequency. The circular polarization of the backfire helix is reversed from the polarization sense of the same helix with a larger ground plane, radiating forward.

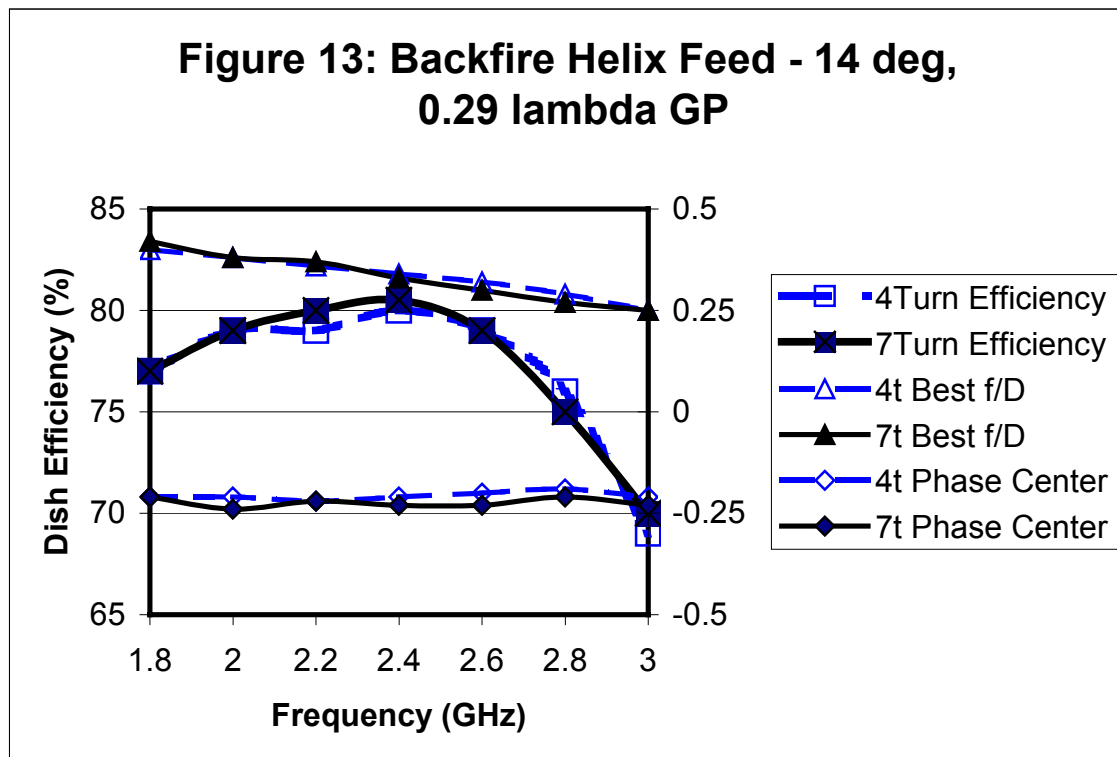

Backfire helix feed, 7 turns 14°, 0.29λ GP, at 2.4 GHz

Figure 12

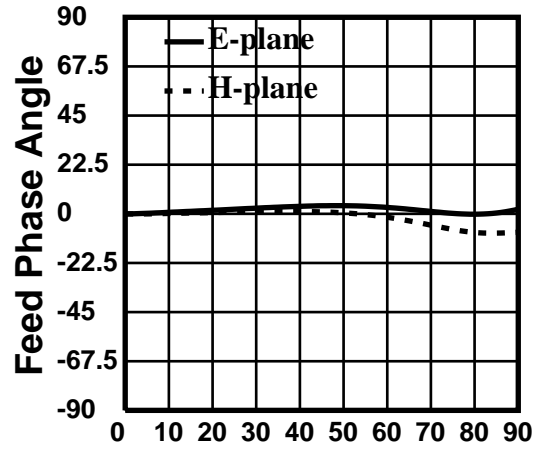
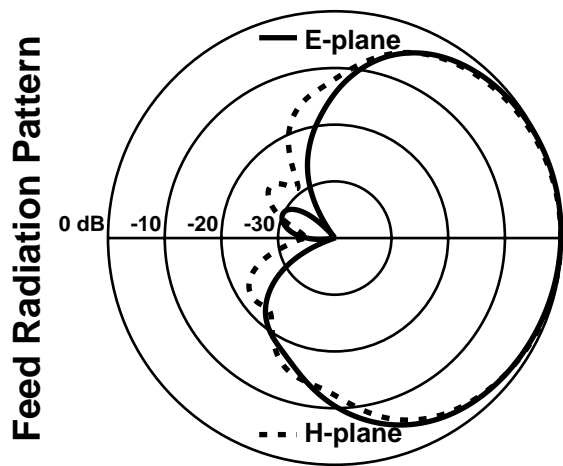

Dish diameter = 10 λ Feed diameter = 0.5 λ

Rotation Angle around specified Phase Center = 0.23 λ inside aperture

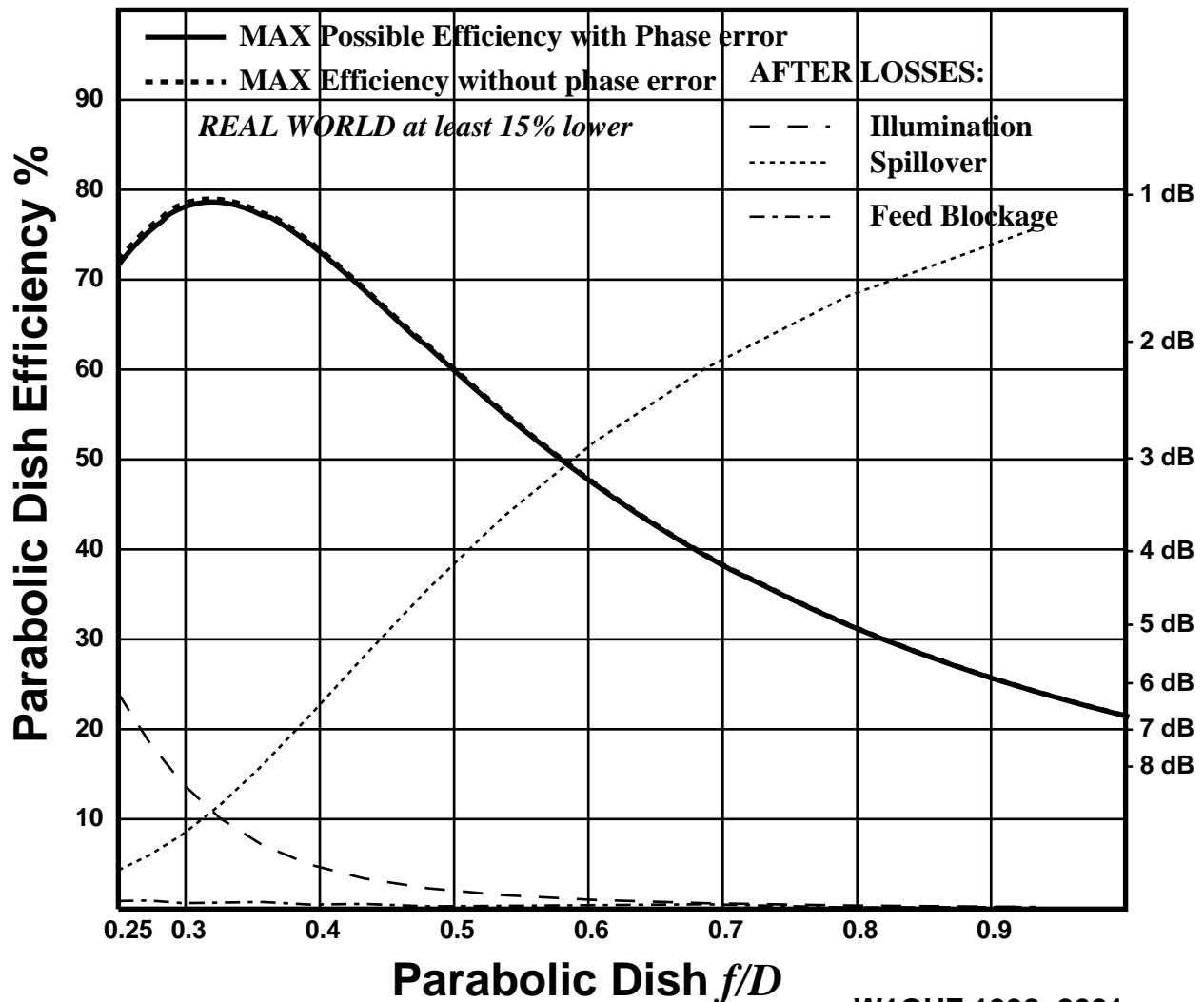

Another feed for deep dishes is the short conical helix¹⁰, with the helix diameter continuously increasing with distance from the ground plane, as shown in Figure 14. I scaled the 4 GHz feed from the original paper to 2.4 GHz, and changed the infinite ground plane to a more realizable 0.94λ in diameter. This makes a pretty good feed for an f/D around 0.4, usable for

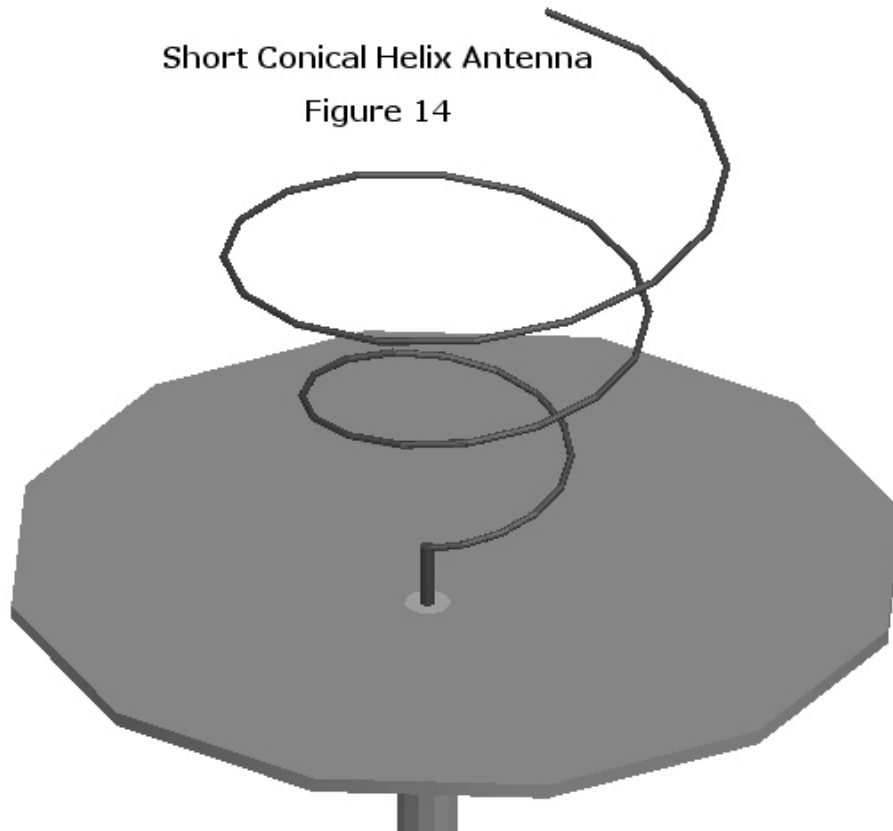

many common prime-focus dishes. The calculated radiation patterns and efficiency are shown in Figure 15 at a frequency of 2.0 GHz, where the performance seemed best. Efficiency was good from 1.6 to 2.4 GHz, but circular polarization was good over a much narrower bandwidth, from about 1.8 to 2.2 GHz. If you experiment with a short conical helix feed, be sure to check the polarization circularity at the operating frequency.

Another possible feed for deep dishes might be a quadrifilar helix. I don't have any patterns for these feeds yet.

Short Conical Helix, 90°, at 2.0 GHz

Figure 15

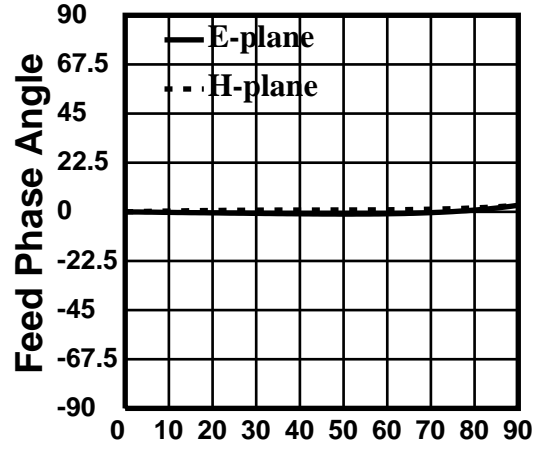
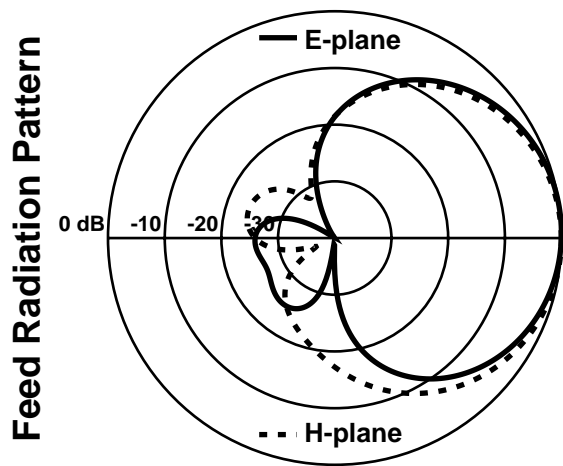

Dish diameter = 10λ Feed diameter = 1λ

Rotation Angle around specified
Phase Center = 0.12λ in front of GP

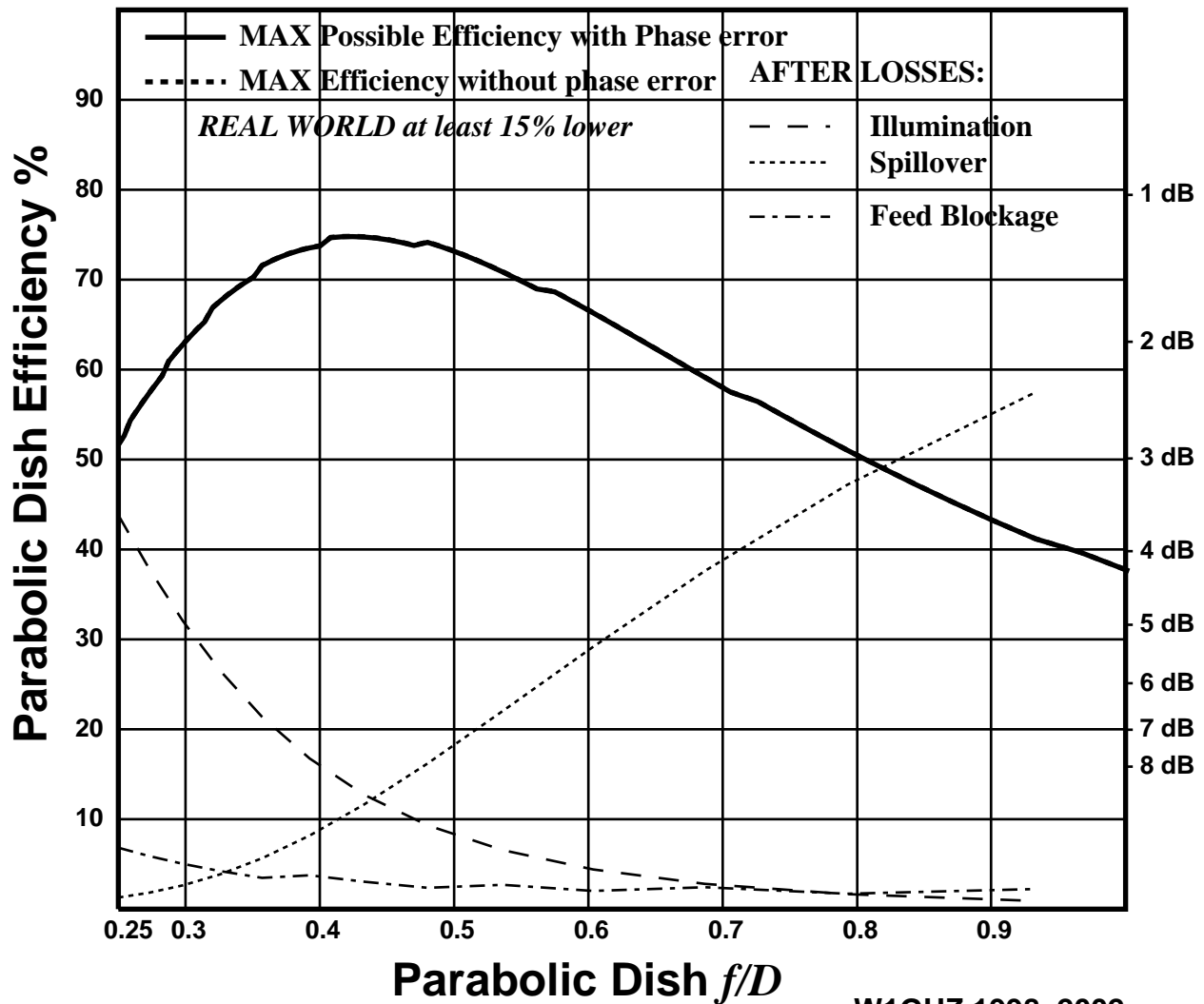

Mechanical considerations

In most cases, a helix made of copper or aluminum wire is not self-supporting, particularly in New England weather. Many helical antenna photographs show a support in the center: one version has a metal center pole with periodic supports for the helix. Another variation winds the wire, like Figure 16, or a flat tape, on a dielectric support. Kraus³ says the dielectric shifts the operating bandwidth to lower frequencies, so that a smaller helix is needed for a given frequency.

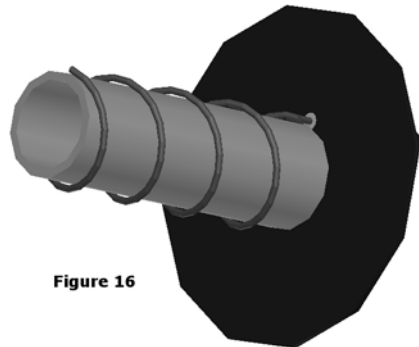

Plastic tubing is readily available in PVC and Fiberglass (FR4), so I calculated patterns for a 4 turn, 12.5° pitch helix with each of these materials. The wall thickness was 3mm, or about 1/8 inch.

Figure 17: Helix feed with dielectric support tube

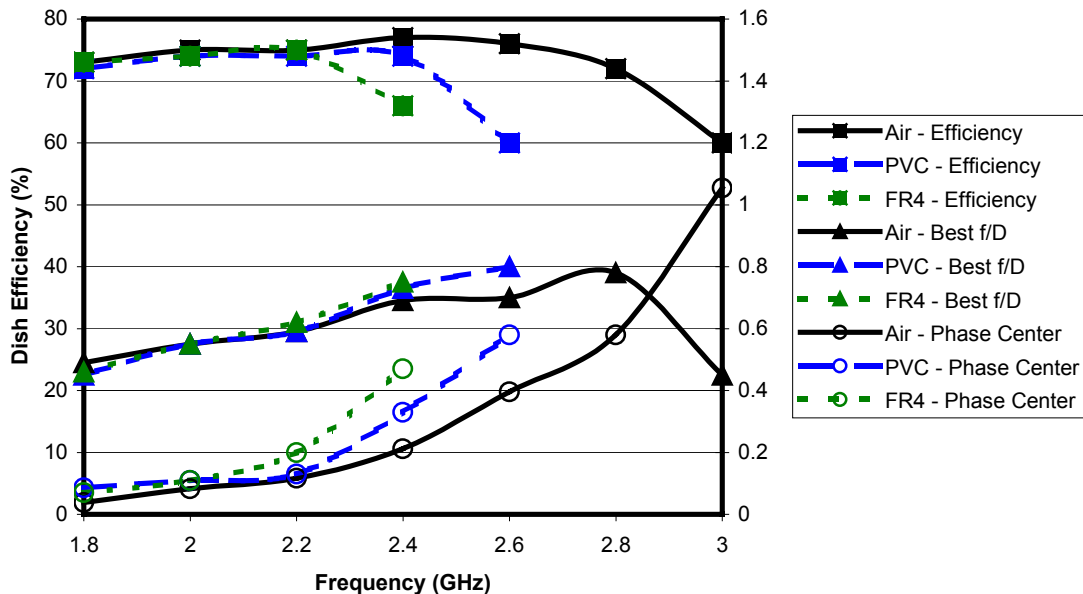

The efficiency with the two dielectric tubes is compared to a helix with no support in Figure 17 and shows a definite decrease in the maximum frequency, about 13% for the PVC and about 20% for the fiberglass. Thus, the size of a helix antenna using these support tubes should probably be reduced accordingly.

I also calculated patterns with a metal center pole, assuming that the support points are small enough to ignore. The 4-turn, 12.5° helix of Figure 4 showed little change with a 1/2" (12.7 mm) diameter pole inside the 40 mm diameter helix, but a 1" (25.4 mm) diameter pole significantly reduced the efficiency. Figure 18 adds curves for both poles to Figure 4. The length of the pole had little effect, so the pole can be short, just supporting the helix, or long enough to support the feed on the dish.

Figure 18: Helix feeds with central support pole

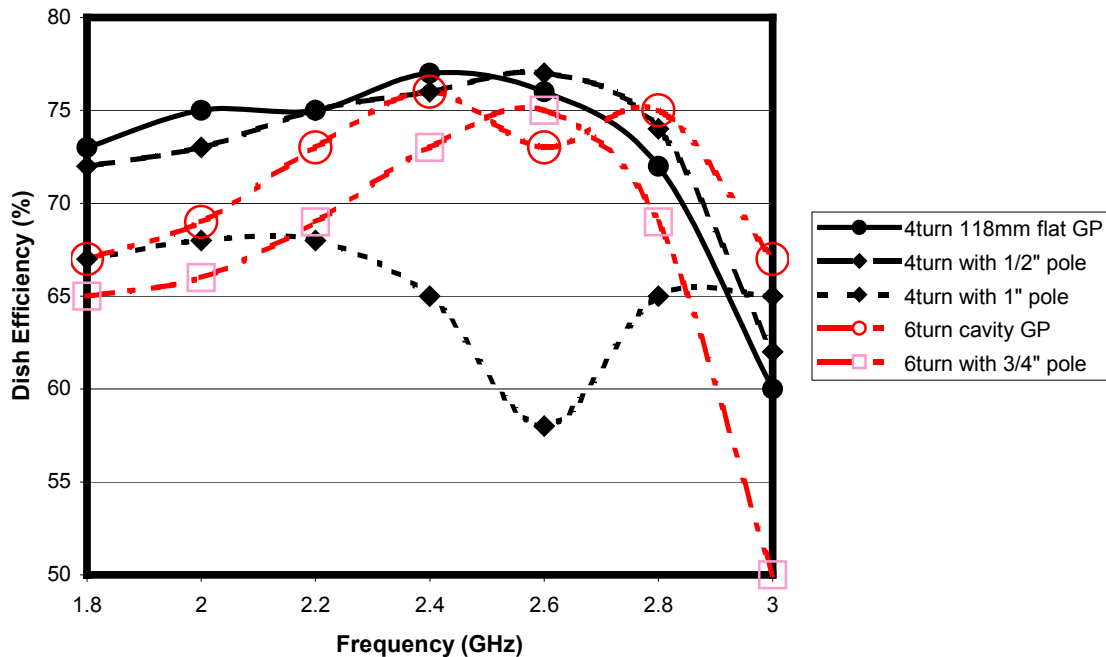

A second example adds a 3/4" (19 mm) pole to the K5OE helical feed, with little change in efficiency, as shown in Figure 18.

We can conclude that a central pole with a diameter less than half the helix diameter does not significantly degrade performance, as long as the supports for the helix wire are small and infrequent.

Feed impedance

A typical helical antenna has an input impedance of around 140 ohms. Kraus³ gives a nominal impedance of $Z = 140C_\lambda$ with axial feed. This is a resistive impedance only at one frequency, probably near the center frequency. Matching the impedance to 50 ohms over a broad bandwidth would be more difficult than simply matching it well for a ham band. A simple quarter-wave matching section with a $Z_0 \sim 84$ ohms should do the trick for a single band. The matching section¹⁰ is often part of the helix: a quarter-wave of wire close to the ground plane before the first turn starts. It could also be on the other side of the ground plane, to separate impedance matching from the radiating element.

Polarization

Circular polarization has two possible senses: right-hand (RHCP) and left-hand (LHCP). Since a helix cannot switch polarization, it is important to get it right: by the IEEE definition³, RHCP results when the helix is wound as though it were to fit in the threads of a large screw with normal right-hand threads. Note that the classical optics definition of polarization is opposite to the IEEE definition.

More important for a feed is that the sense of the polarization reverses on reflection, so that for a dish to radiate RHCP polarization requires a feed with LHCP. For EME, reflection from the moon also reverses circular polarization, so that the echo returns with polarization reversed from the transmitted polarization. A helical feed used for EME would not be able to receive its own echoes because of cross-polarization loss.

Summary

The helical antenna is an excellent feed for circular polarization. It is broadband and dimensions are not critical, and the patterns are well-suited to illumination of offset dishes. It is a particularly good feed for small offset dishes for satellite applications.

References

1. Kraus, J.D., (W8JK), "A Helical-Beam Antenna Without a Ground Plane," *IEEE Antennas and Propagation Magazine*, April 1995, p. 45.
2. Kraus, J.D., *Antennas*, McGraw-Hill, 1950.
3. Kraus, J.D. & Marhefka, R.J., *Antennas: for All Applications, third edition*, McGraw-Hill, 2002.
4. Emerson, D., AA7FV, "The Gain of the Axial-Mode Helix Antenna," *Antenna Compendium Volume 4*, ARRL, 1995, pp. 64-68.
5. <http://ourworld.compuserve.com/homepages/demerson/helix.htm> or <http://www.tuc.nrao.edu/~demerson/helixgain/helix.htm>
6. www.zeland.com
7. www.ansoft.com
8. The *unofficial* Numerical Electromagnetic Code (NEC) Archives, by WB6TPU, <http://www.qsl.net/wb6tpu/swindex.html>
9. Nakano, H., Yamauchi, J., & Mimaki, H., "Backfire Radiation from a Monofilar Helix with a Small Ground Plane," *IEEE Transactions on Antennas and Propagation*, October 1988, pp. 1359-1364.
10. Nakano, H., Mikawa, T., & Yamauchi, J., "Investigation of a Short Conical Helix Antenna," *IEEE Transactions on Antennas and Propagation*, October 1985, pp. 1157-1160.
11. Kraus, J.D., "A 50-Ohm Impedance for Helical Beam Antennas," *IEEE Transactions on Antennas and Propagation*, November 1977, p. 913.