

## Chapter 6

### Feeds for Parabolic Dish Antennas

*Paul Wade W1GHZ © 1994,1997,1998,1999*

#### Section 6.3 Circular waveguide feeds

Another simple antenna useful as a feed antenna is a cylindrical horn, a fancy name for a round pipe radiating from the open end. At the proper frequencies, a round pipe acts as a cylindrical waveguide. Energy propagating through the waveguide will continue propagating past an open end, radiating into free space. Several feed antennas start with the unadorned horn and add features to improve performance as a feed antenna.

##### 6.3.1 “Coffee can” feeds

**“Coffee can” feed** — The “Coffee can” feed is simply an open-ended circular, or cylindrical, waveguide. Early USA amateur versions<sup>1</sup> used coffee cans as raw material — a 3-pound can for 23 cm or a one-pound can for 13 cm. The diameter of the cans supports waveguide propagation at these frequencies, and the tinned steel is solderable and reasonably robust, enabling low-cost homebrewing of a feed with decent performance. The simplicity of this feed and the ready availability of tinned cans have inspired use on higher bands<sup>2</sup> as well.

The illumination angle provided by a cylindrical horn feed is inversely proportional to the waveguide diameter, so that it can be tailored for a desired  $f/D$  by choosing the appropriate diameter. A popular size has a waveguide diameter of  $0.76\lambda$ , so I used NEC2 to calculate the radiation pattern shown in Figure 6.3-1; published patterns measured by VE4MA<sup>3</sup> and Jasik<sup>4</sup> are similar. The performance graph in Figure 6.3-1 has best efficiency at an  $f/D$  around 0.35 to 0.4. However, the calculated peak efficiency is about 67%, and it is unlikely to be this high in practice; I would expect a real efficiency closer to 50%. The phase center is at the center of the aperture, the mouth of the horn.

Estimation of the waveguide diameter required illumination a dish requires a bit of calculation. Assuming that the  $f/D$  of the dish is known, the graph of Figure 6.0-2 may be used to find the required illumination angle and space attenuation. Then the feed taper may be calculated by subtracting the space attenuation from the desired taper (frequently 10 dB taper), as described in Section 6.0.

# Coffee can feed, $0.76\lambda$ diameter, by NEC2

## Figure 6.3-1

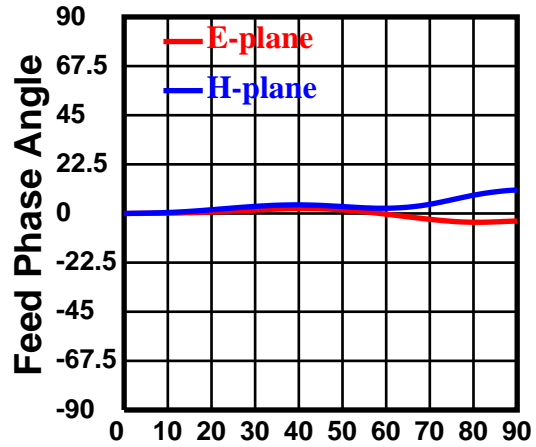
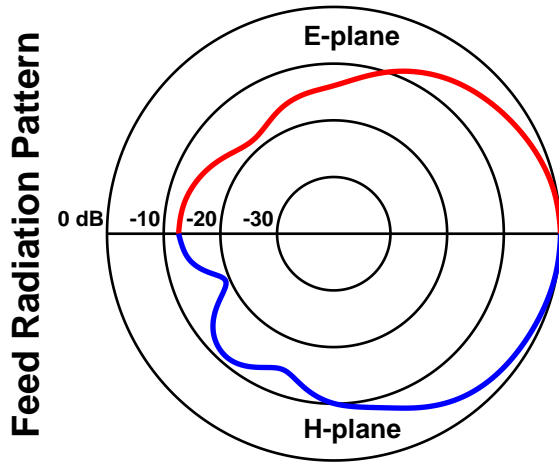

Dish diameter =  $10\lambda$  Feed diameter =  $1\lambda$

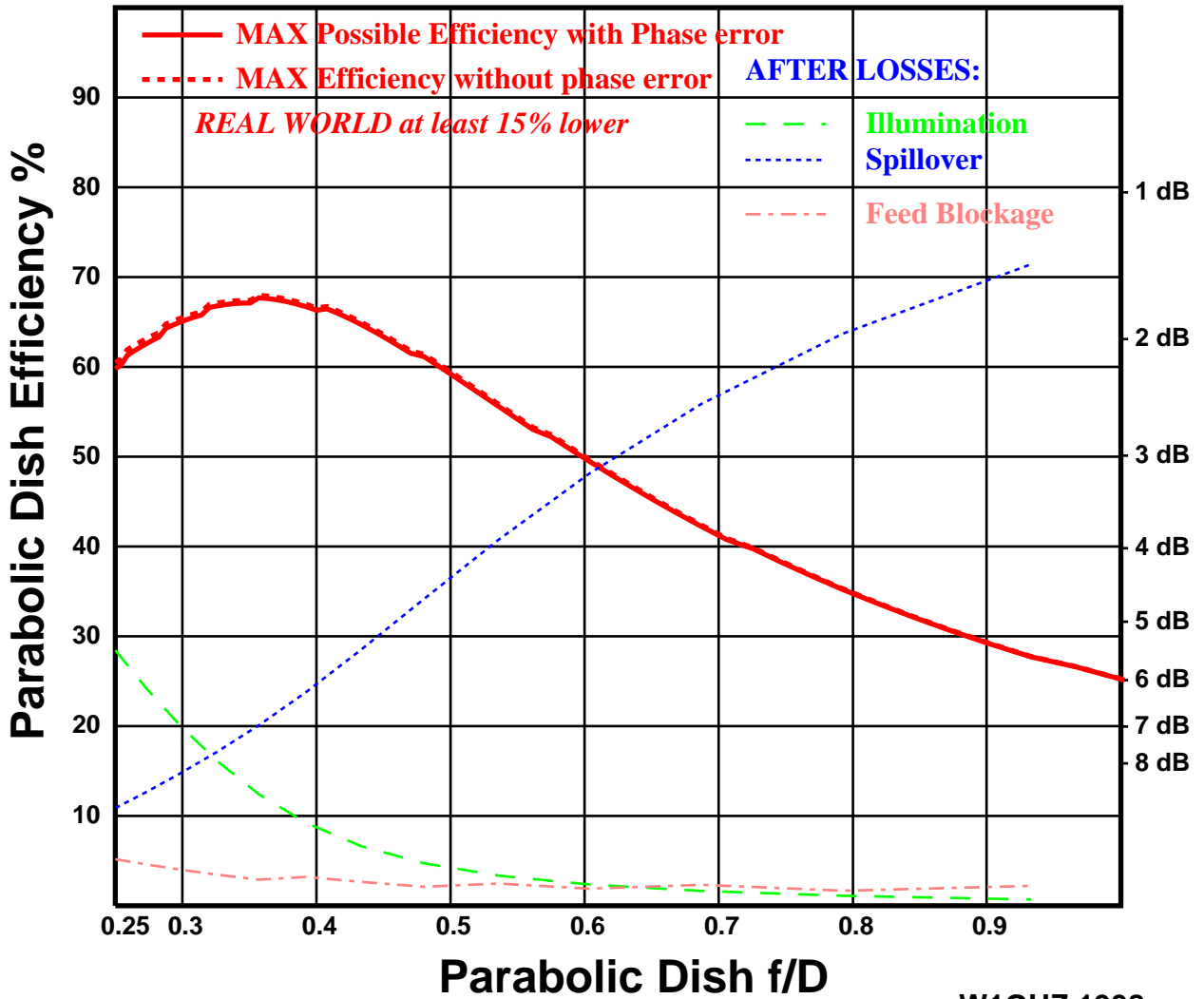

For a cylindrical horn, the approximate 3-dB beamwidth is:

$$\mathbf{BW}_{3\text{dB}} \cong \frac{66}{\mathbf{Diameter}_\lambda} \text{ degrees}$$

To find the  $\mathbf{BW}_{3\text{dB}}$  that will provide the desired feed taper for an illumination angle  $\theta$ , we can use Kelleher's<sup>5</sup> universal horn patterns from Chapter 2:

$$\mathbf{BW}_{3\text{dB}} \cong \theta \cdot \sqrt{\frac{3}{\mathbf{Desired\_taper} \text{ (in dB)}}} \text{ degrees}$$

and then reverse the previous equation to calculate the cylindrical horn diameter in wavelengths:

$$\mathbf{Diameter}_\lambda \cong \frac{66}{\mathbf{BW}_{3\text{dB}}} \text{ wavelengths}$$

An easier approach might be to let the **HDLANT** program do all the required calculations.

How wide a range of  $f/D$  may be accommodated by horn diameter? First, the horn must be large enough for the lowest order waveguide mode, the  $\mathbf{TE}_{11}$  mode, to propagate. The cutoff wavelength for this mode is  $1.706 \times \text{Diameter}$  so the minimum waveguide diameter is  $0.59\lambda$ . Figure 6.3-2 shows the radiation pattern for a circular horn  $0.60\lambda$  in diameter, just barely larger than the cutoff dimension. The efficiency plot shows a peak at  $f/D$  about 0.25, as deep a dish as is practical. Best efficiency is not as good as the larger version, but is pretty good for a very deep dish. The phase center is  $0.1\lambda$  beyond the horn aperture, in front of the mouth of the horn.

Moving in the other direction, a large horn diameter would permit additional higher-order waveguide modes to propagate, radiate, and affect the radiation pattern. The next mode,  $\mathbf{TM}_{01}$ , needs a minimum diameter of  $0.76\lambda$ , so that any horn larger than our first example might have additional modes. The radiation pattern for a slightly larger horn,  $0.86\lambda$  in diameter, is shown in Figure 6.3-3, with the **E**- and **H**-planes well balanced. As a result, the efficiency plot shows very good efficiency at  $f/D$  around 0.4, with the phase center  $0.07\lambda$  beyond the horn aperture.

No ill effects from higher-order modes are apparent in Figure 6.3-3. However, when the horn diameter is increased further, to  $0.95\lambda$ , we start to see some changes. The radiation patterns (note that these patterns show the full **E**- and **H**-plane patterns, unlike previous ones which only show one-half the pattern and assume symmetry) in Figure 6.3-4 show a significant difference between the **E**- and **H**-plane patterns. The **E**-plane pattern is skewed to one side so that the antenna does not peak on boresight. If this horn were used as a feed, the dish would probably have squint, or aiming error to one side. Since the phase was also skewed, I did not attempt to calculate the efficiency with phase error.

# Coffee can feed $0.60\lambda$ diameter, by NEC2

## Figure 6.3-2

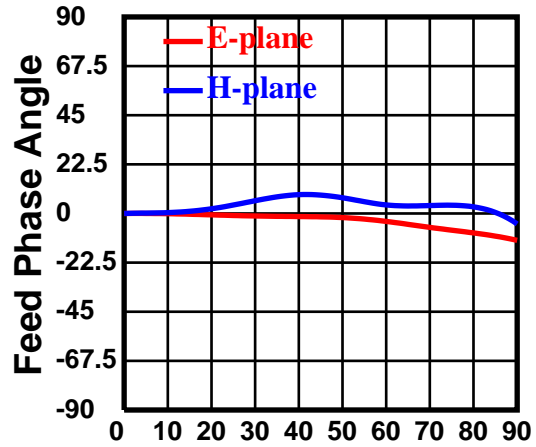
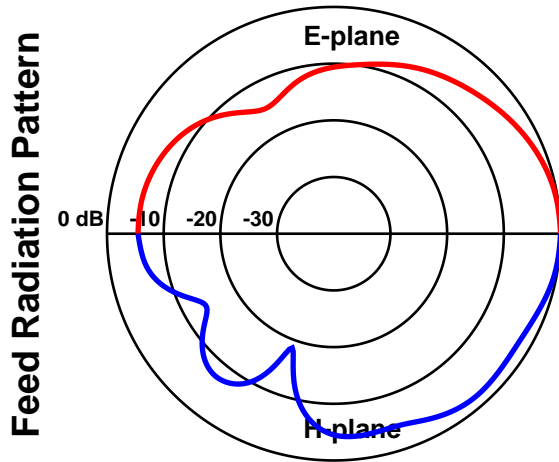

Dish diameter =  $10\lambda$  Feed diameter =  $1\lambda$

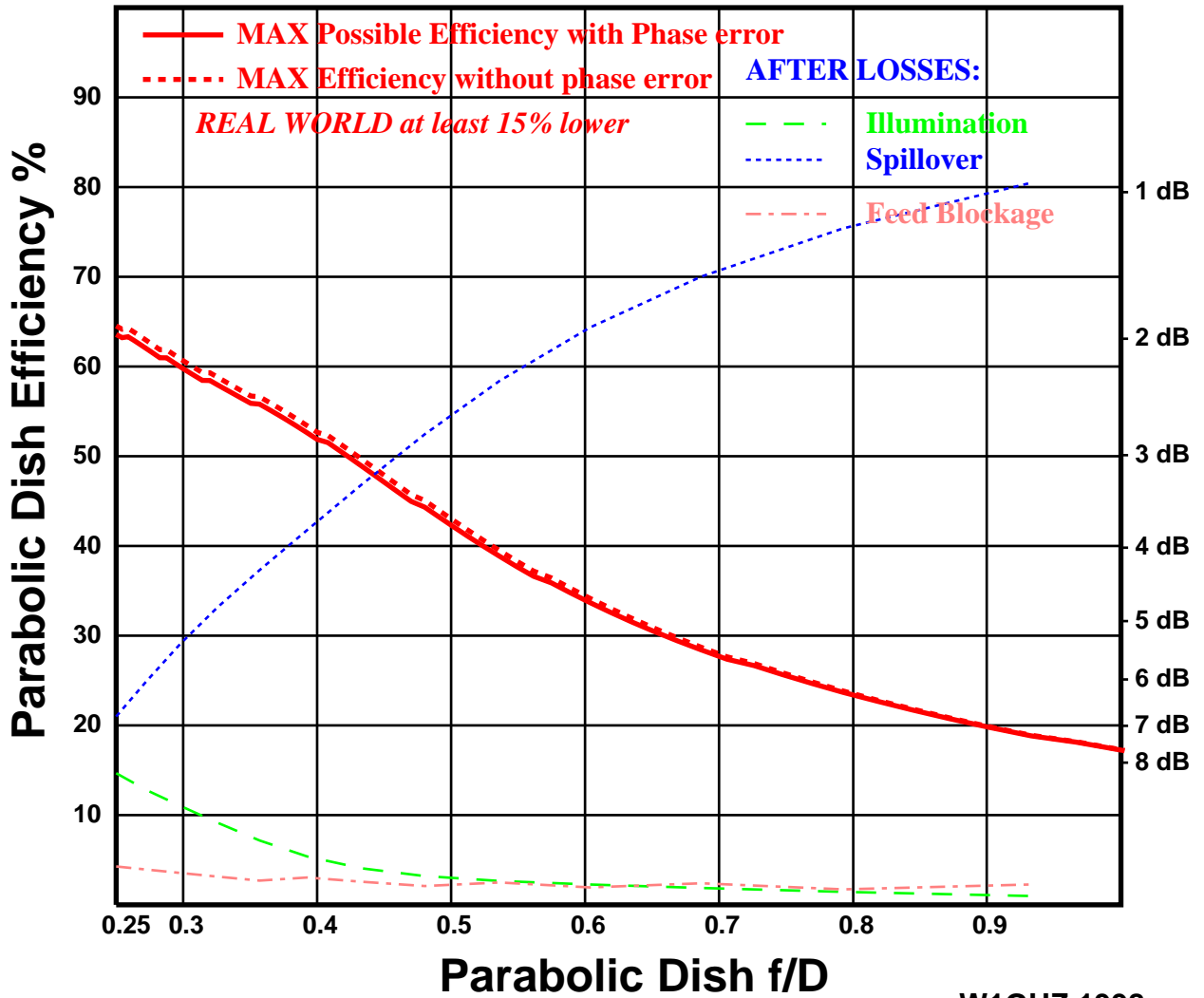

# Coffee can feed $0.86\lambda$ diameter, by NEC2

## Figure 6.3-3

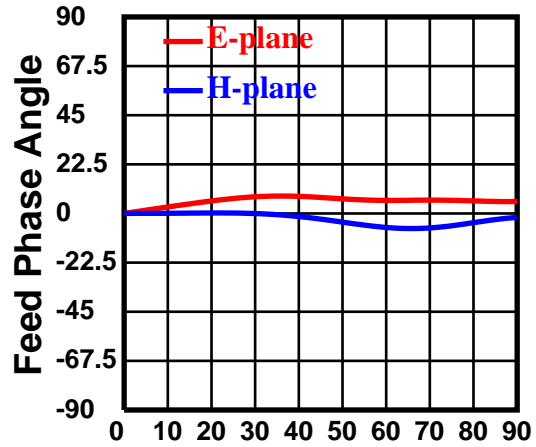
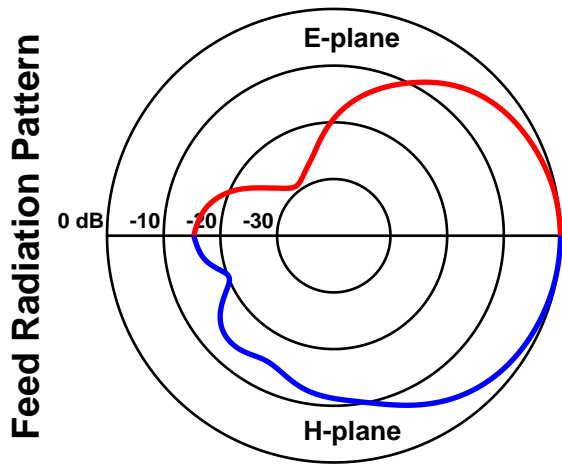

Dish diameter =  $10\lambda$  Feed diameter =  $1\lambda$

Phase Center =  $0.07\lambda$  beyond aperture

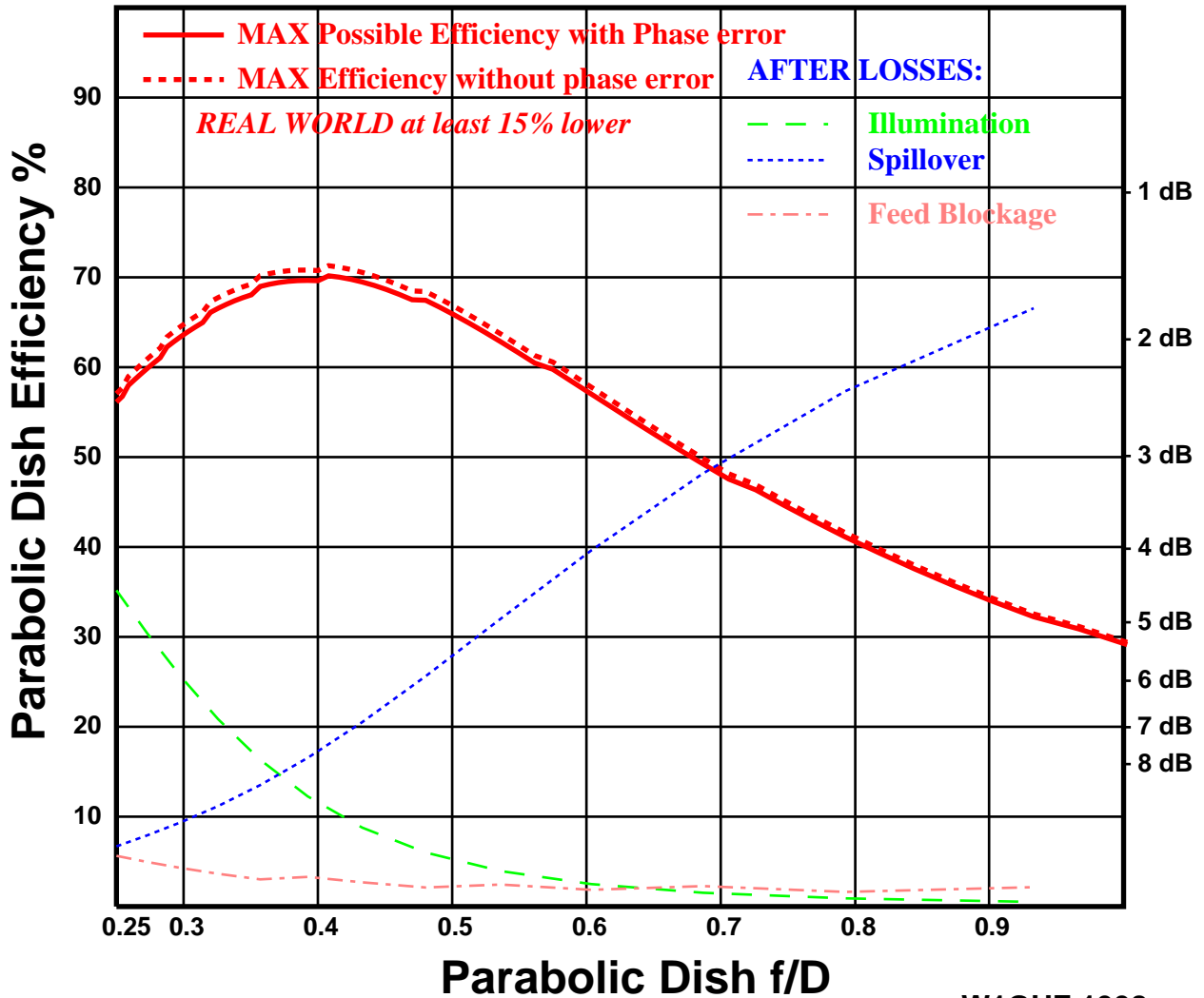

# Coffee can feed $0.95\lambda$ diameter, by NEC2

Figure 6.3-4

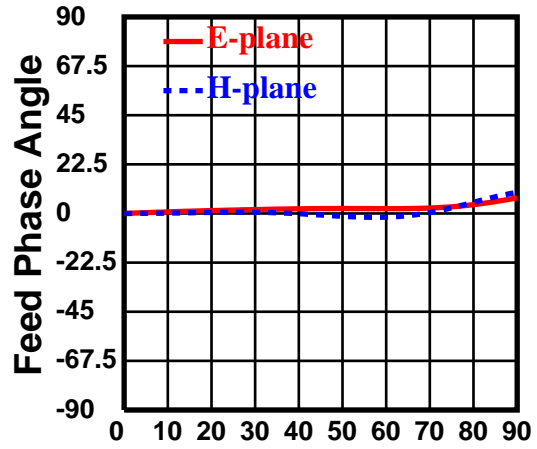
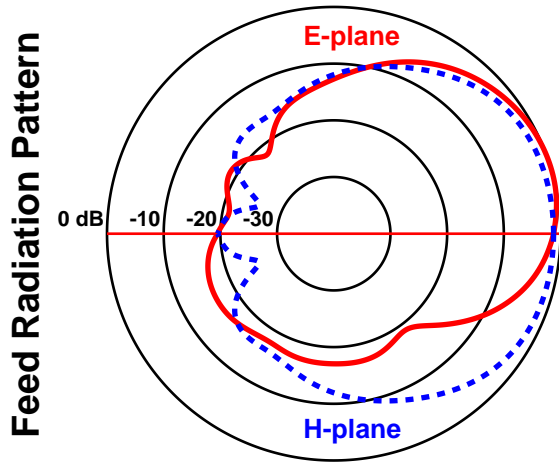

Dish diameter =  $10\lambda$  Feed diameter =  $1\lambda$

Rotation Angle around specified Phase Center =  $0\lambda$  beyond aperture

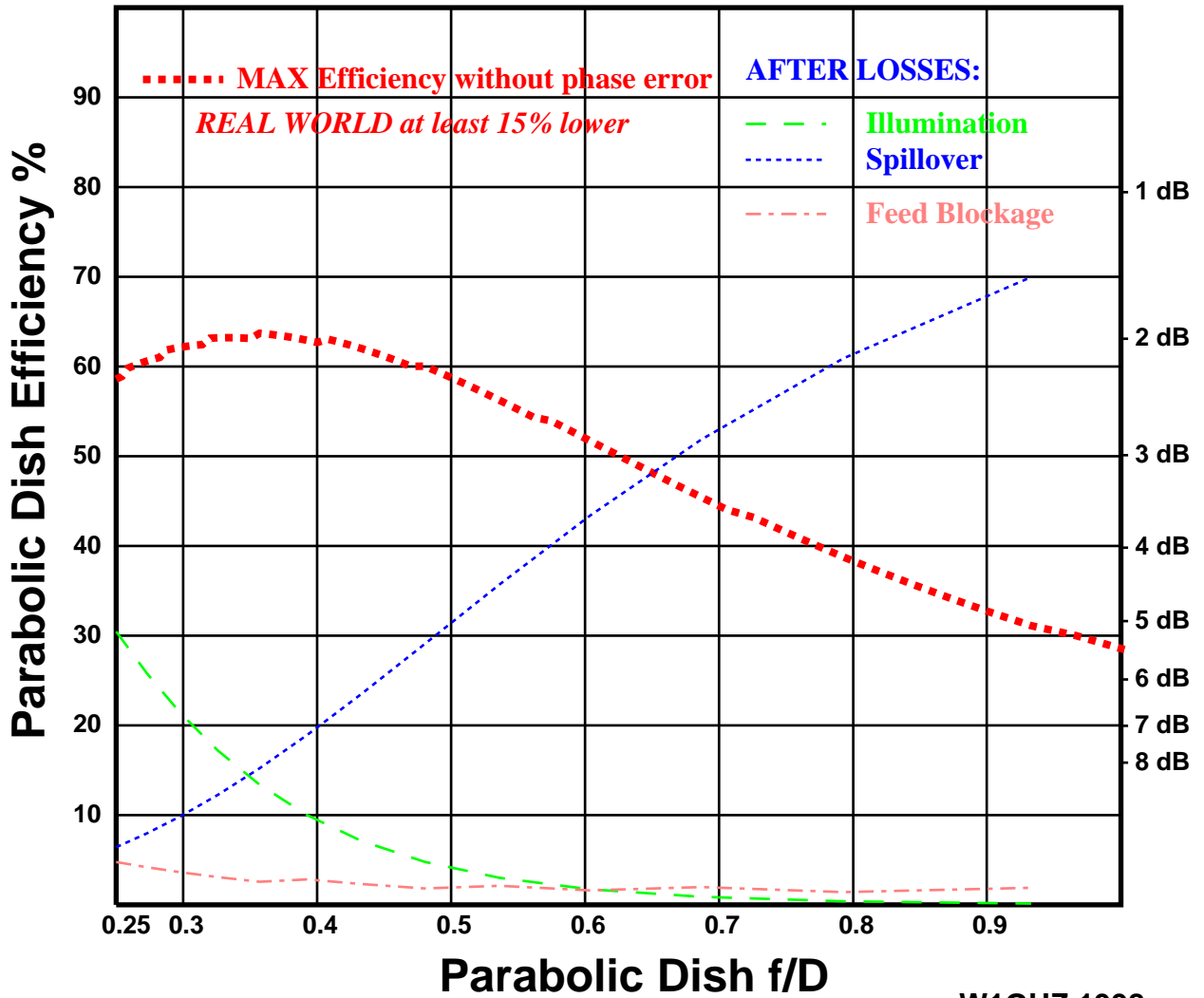

If the horn diameter is increased further, to greater than  $0.97\lambda$ , the **TE** mode can also propagate. I ran the **NEC2** calculations for circular horns with  $1.05\lambda$  and larger diameters, but the patterns were so distorted that simple plots were inadequate — the pattern peaks somewhere off-axis in both dimensions.

From the above examples, we can recommend “coffee-can” feed diameters in the range of about  $0.6\lambda$  to  $0.9\lambda$ , corresponding to an  $f/D$  range of 0.25 to 0.4. Deeper dishes are unlikely, but many dishes have a higher  $f/D$ . Fortunately, a better way to increase the diameter is available — flaring the end of the waveguide into a conical horn, or a pyramidal horn for rectangular waveguide. Flared horns will be discussed in Section 6.4.

The attraction of a coffee-can feed is that it is so simple to make, a matter of finding the right diameter can and soldering a coax connector with probe to one side. Horn length is not critical, but should be more than one waveguide wavelength to eliminate any stray modes launched at the probe transition. My experience with probes in circular waveguide is that they are touchy to adjust and get right; the horn impedance varies with changes in both horn diameter and horn length, so any modification can upset the VSWR. Since many microwave neophytes are unable to measure VSWR at microwave frequencies, a less sensitive coaxial transition would help them to achieve good results.

The problem with simple feeds like the coffee-can is a poor front-to-back ratio, 15 dB or less in the above examples. A significant amount of radiation off the back of the feed obviously misses the reflector, resulting in spillover loss and lower efficiency. The radiation in unwanted directions is the result of “edge currents” in the rim of the horn.

To quote W2IMU<sup>5</sup>, “These currents result from the relatively high **E**-plane fields at the rim of the horn. Surface currents flow transverse to the edge of the horn, resulting in spurious radiation in the form of side and rear lobes from the feed.” The feeds discussed in the rest of this section are basically circular horn feeds with enhancements to reduce the side and rear lobes.

### 6.3.2 Coffee-can with choke flange (WA9HUV)

The simplest enhancement to the circular horn, described by WA9HUV<sup>6</sup>, is to add a choke flange around the horn. This is simply a flat disk with the horn passing through the center; with the proper dimensions, it should reduce the backward radiation. Figure 6.3-5 shows the pattern calculated by **NEC2** for a  $0.76\lambda$  diameter circular horn with a  $2\lambda$  diameter choke flange attached  $0.27\lambda$  behind the mouth of the horn. Compared to the plain horn in Figure 6.3-1, the front-to-back ratio is improved and unwanted sidelobes are greatly reduced. As a result, the calculated efficiency is significantly improved over the plain horn. The phase center remains very close to the center of the aperture.

WA9HUV later added slots<sup>7</sup> to the flange, to make the patterns in the **E**- and **H**-planes more symmetrical. I have not modeled this configuration.

It is my understanding that the flange dimensions are fairly critical to achieve the high performance shown in Figure 6.3-5, but I haven’t experimented with different flange dimensions or horn diameters. Here is an opportunity for someone to experiment further!

# WA9HUV feed, $0.76\lambda$ dia horn with choke flange, by NEC2

## Figure 6.3-5

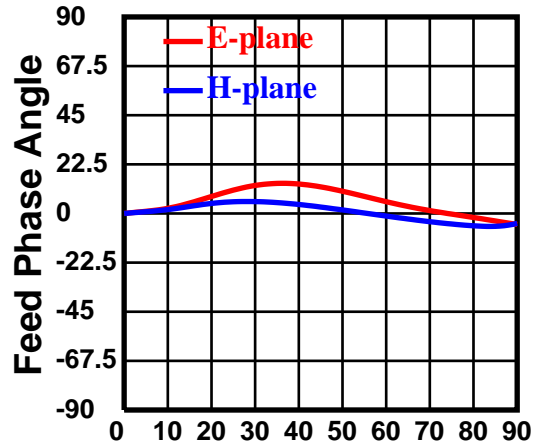
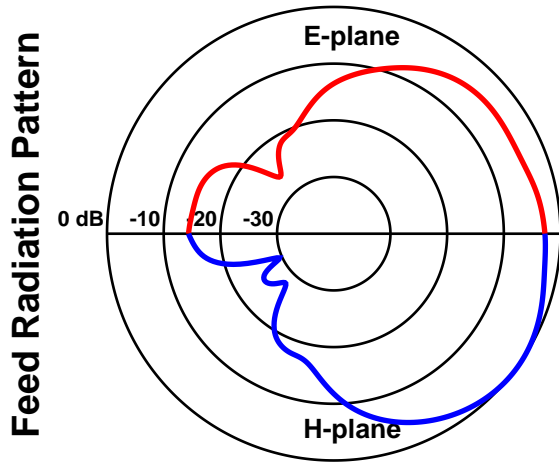

Dish diameter =  $20\lambda$  Feed diameter =  $2\lambda$

Rotation Angle around specified Phase Center =  $0\lambda$  beyond aperture

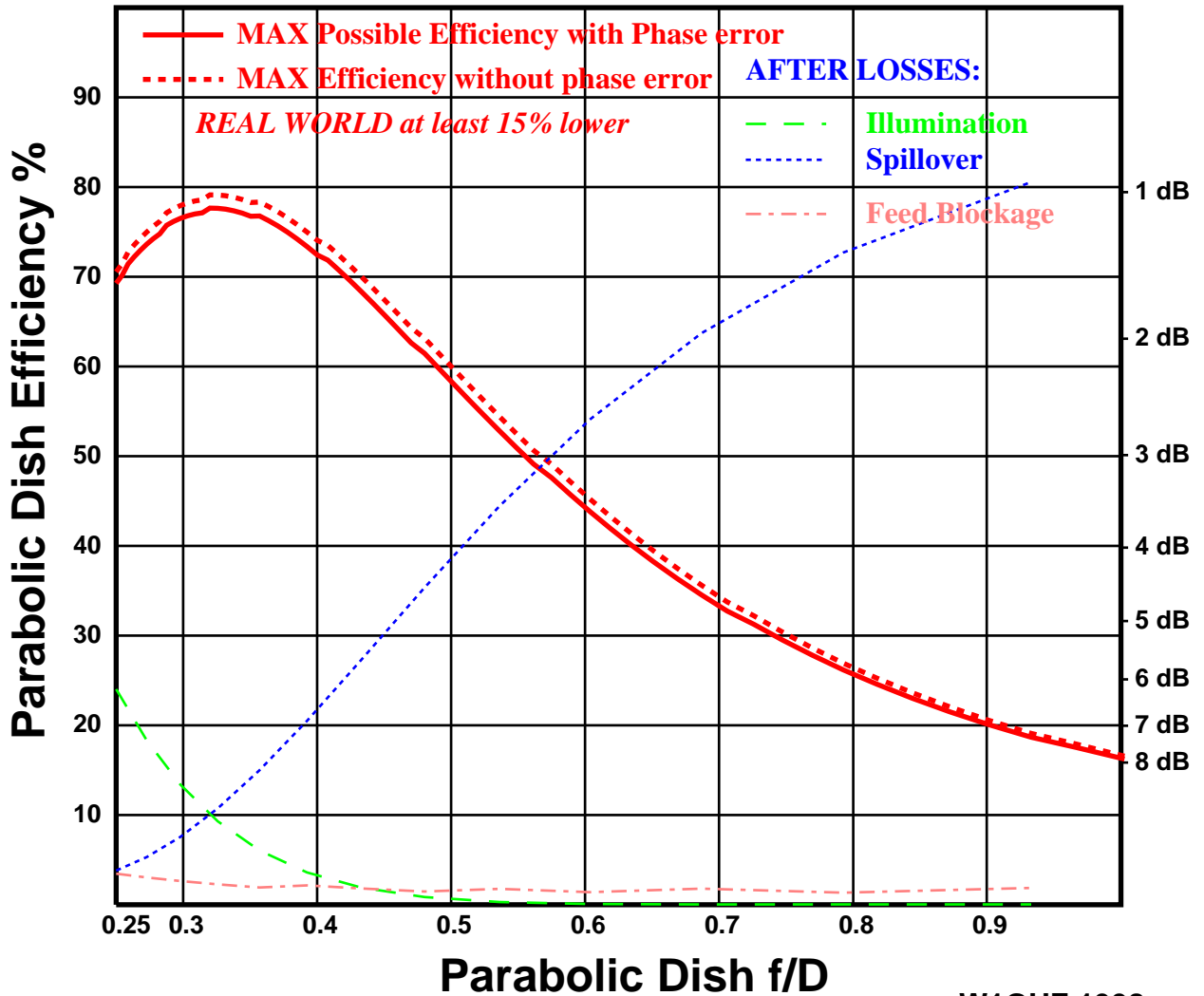



### 6.3.3 VE4MA feed

A further improvement to the cylindrical horn, described by Kumar<sup>8</sup>, is to replace the choke flange with a cavity choke ring around the horn, roughly  $\frac{1}{2}\lambda$  wide and  $\frac{1}{2}\lambda$  deep. This ring, which W2IMU<sup>5</sup> calls a low-Q trap, should have broader bandwidth and be less critical than a choke flange. VE4MA refined this into a working feedhorn<sup>3</sup> and measured the performance. This feed has been scaled by VE4MA and others for most of the amateur microwave bands<sup>3,9,10,11,12,13</sup>. A sketch of this feed is shown Figure 6.3-6 with dimensions for several of the microwave ham bands, and a photo of one example is shown in Figure 6.3-7. In Figure 6.3-8, the radiation pattern for the 1296 MHz version, with a horn diameter of  $0.76\lambda$ , as calculated by NEC2, is compared with the pattern measured by VE4MA (green dashed line — rear half of pattern is from Kumar). The performance plot shows very good efficiency for an  $f/D$  around 0.4 to 0.45, higher than the simple coffee-can feed. Kumar's data shows excellent phase performance for this style feed for a rotation angle up to about  $\pm 72^\circ$ , and the calculated pattern agrees. The calculated phase center is  $0.07\lambda$  beyond the aperture, in front of the mouth of the horn, so that the mouth of the horn should be farther away from the dish than the focal point.

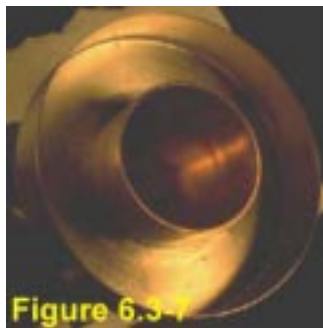

The excellent performance of the VE4MA feeds has been proven by many microwave EME stations. They are reproducible using the published dimensions in Figure 6.3-6 by amateur construction techniques, and the size and weight are reasonable. This feed is highly recommended for dishes with  $f/D$  around 0.3 to 0.45; the position of the outer choke ring may be adjusted to fine-tune the feed to a particular  $f/D$ , according to VE4MA<sup>9</sup>. I experimented with moving the position and calculated radiation patterns at several choke locations. Figure 6.3-9 shows the pattern with the choke ring moved back so that the horn projects by  $0.34\lambda$ . The efficiency plot shows best  $f/D$  is about 0.33 for this case. To show the effect of ring location, the efficiency plot also includes the curve with the horn flush with the rings, from Figure 6.3-8, and an intermediate position, with the horn projecting  $0.17\lambda$  and best  $f/D$  of about 0.33. The phase center in all cases is close to the center of the aperture; it moves slightly in the same direction as the choke ring is moved.

In Figure 6.3-9 we can clearly see the pattern control available by moving the choke ring position. VE4MA's data also indicates that the pattern could be adjusted for a larger  $f/D=0.5$  by adjusting the ring so that the mouth of the horn is inside the ring by  $0.025\lambda$ . The calculated pattern in Figure 6.3-10 does not support this; positioning the horn further inside the rings moves the peak in the other direction, back toward smaller  $f/D$ . On the other hand, Barry made actual measurements on a real feed — these figures are only computer simulations.

In addition to the limited  $f/D$  tuning by moving the choke ring, it should be possible to vary the diameter of the central horn over the same range as the coffee can. I have not experimented with this except for one example. K1DPP and I fabricated one for 5760 MHz using available materials, which required compromising the dimensions<sup>14</sup> a bit; the horn diameter was  $0.95\lambda$ . Dish gain measurements at the time indicated that the feed seemed to work, but NEC2 pattern calculation, shown in Figure 6.3-11, show a pattern skewing similar to the same diameter coffee-can feed in Figure 6.3-4.

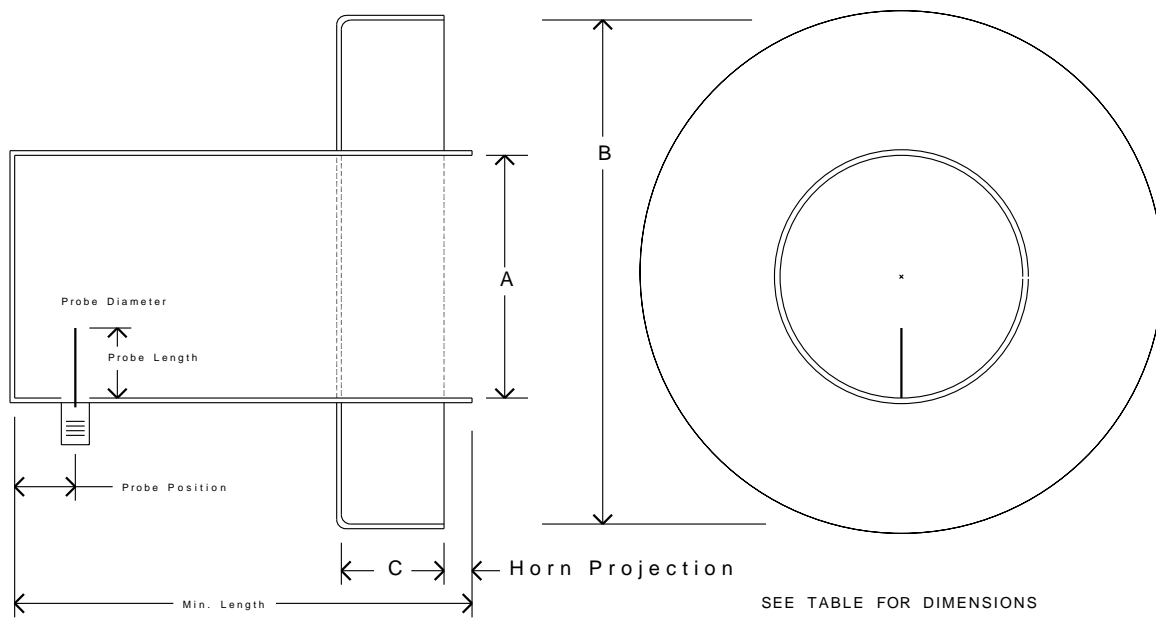

Frequency	A	B	C	Reference
1296 MHz	178 mm	419 mm	121 mm	3,9
2304 MHz	100 mm	240 mm	62.5 mm	3,9
3456 MHz	66 mm	160 mm	42 mm	10
5760 MHz	39 mm	90 mm	26.5 mm	11,12
10368 MHz	20.5 mm	50 mm	12.5 mm	13

**Figure 6.3-6 VE4MA (Kumar) Feed**

# VE4MA 1296 feed with flush choke ring, by NEC2

## Figure 6.3-8

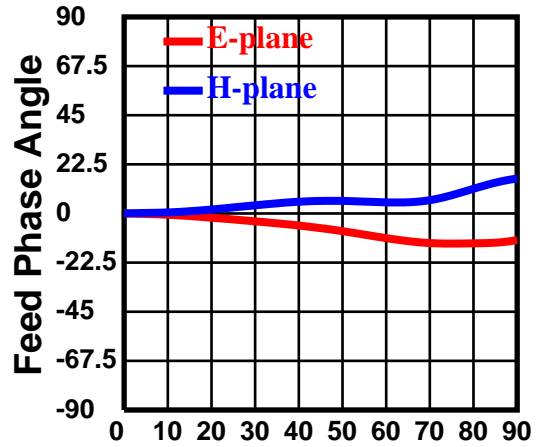
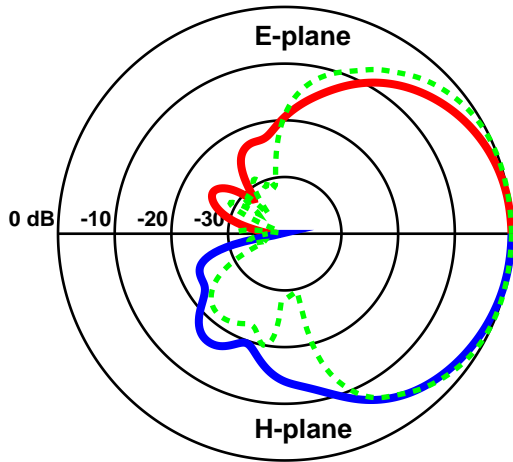

Dish diameter =  $18.4 \lambda$  Feed diameter =  $1.84 \lambda$

Rotation Angle around specified Phase Center =  $0.07 \lambda$  beyond aperture

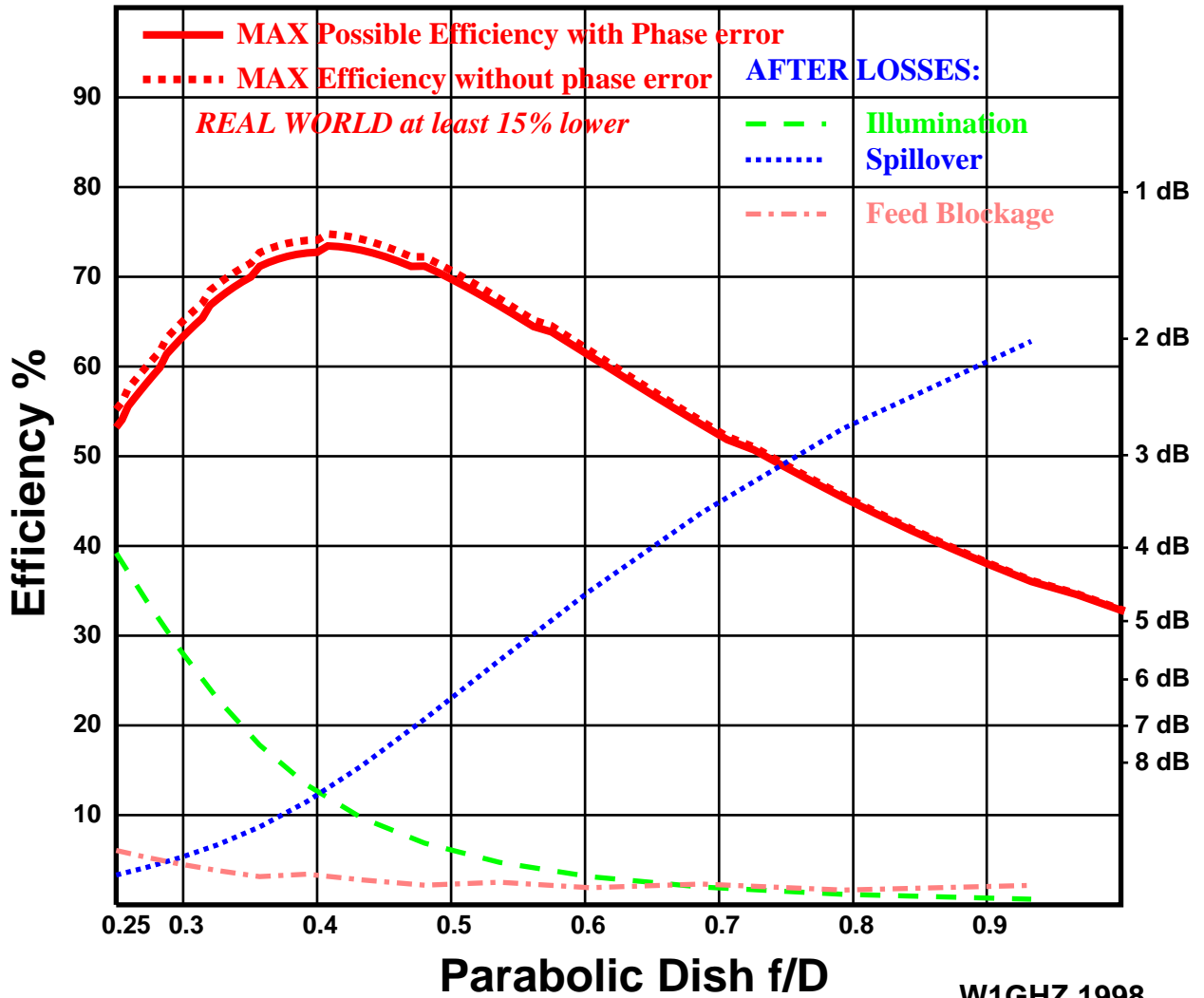

# VE4MA 1296 feed - adjusting for $f/D$ , by NEC2

## Figure 6.3-9

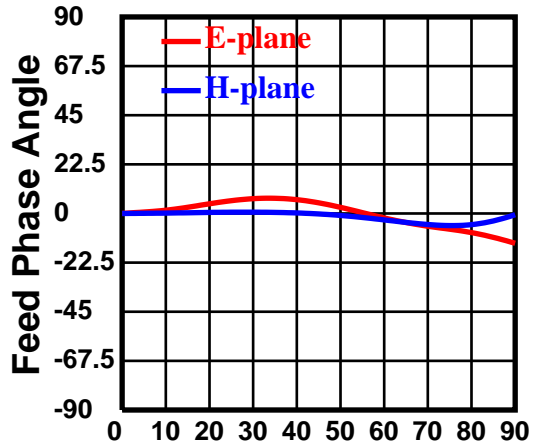
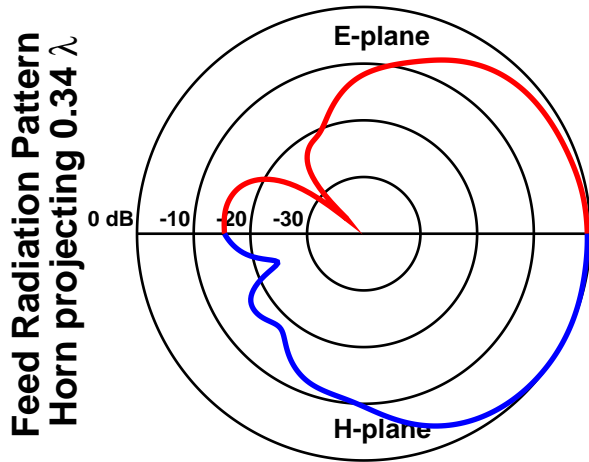

Dish diameter =  $18.4 \lambda$  Feed diameter =  $1.84 \lambda$

Rotation Angle around specified  
Phase Center =  $0 \lambda$  beyond aperture

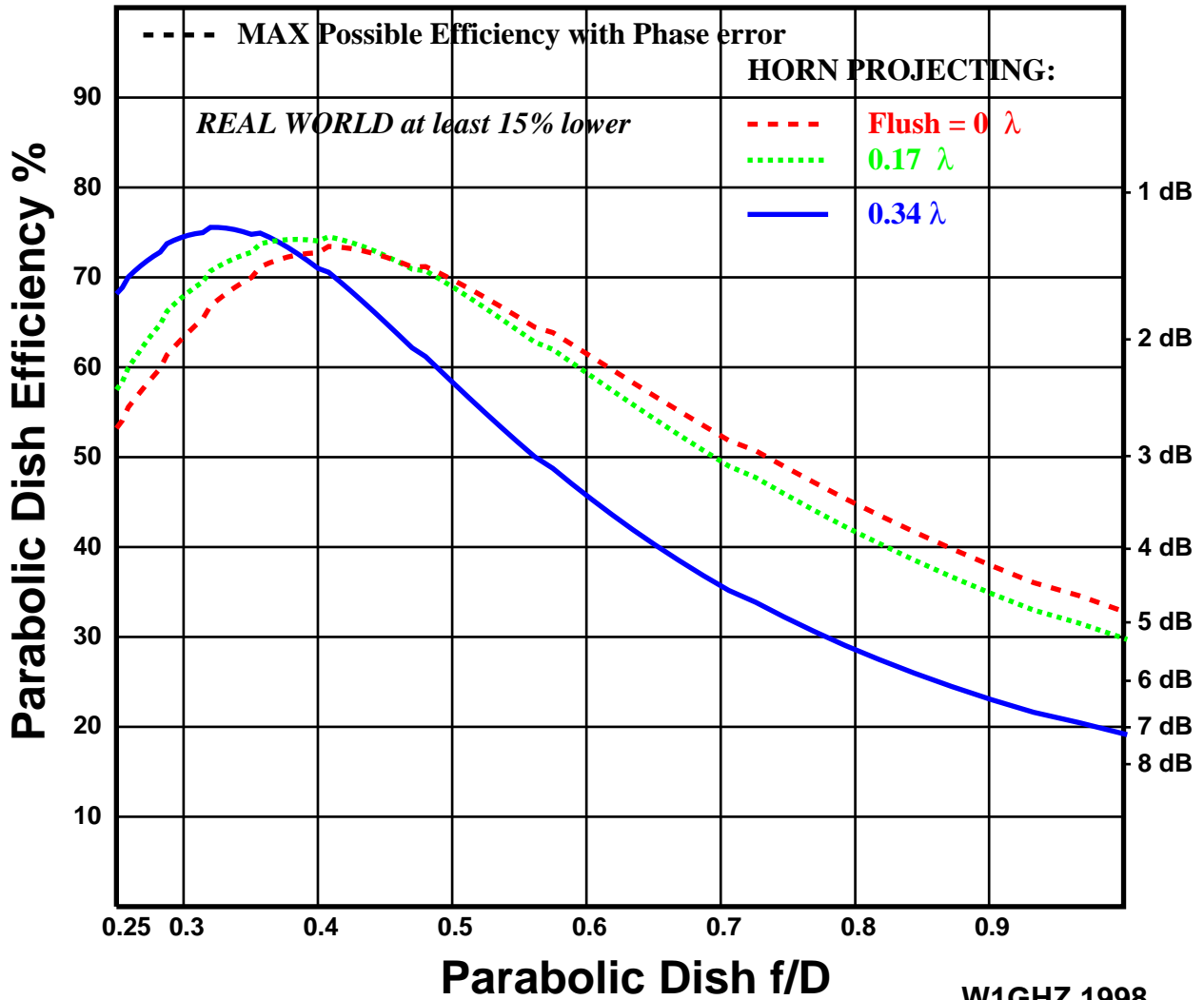

**VE4MA feed,  $0.76\lambda$  dia horn,  $0.025\lambda$  inside choke rings, by NEC2**

**Figure 6.3-10**

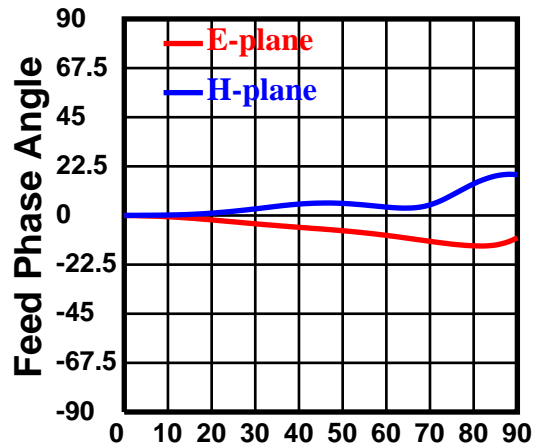
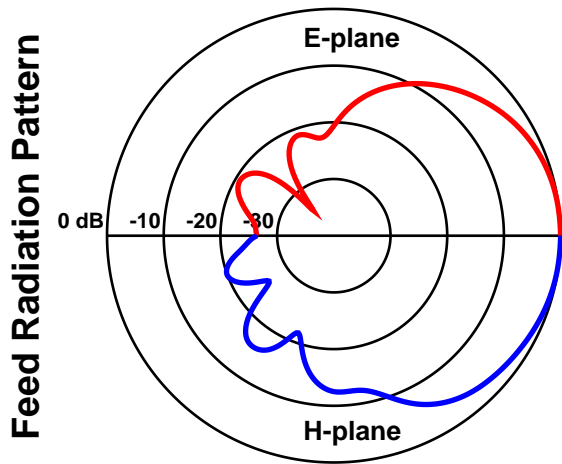

Dish diameter =  $18\lambda$  Feed diameter =  $1.8\lambda$

Rotation Angle around specified Phase Center =  $0.07\lambda$  beyond aperture

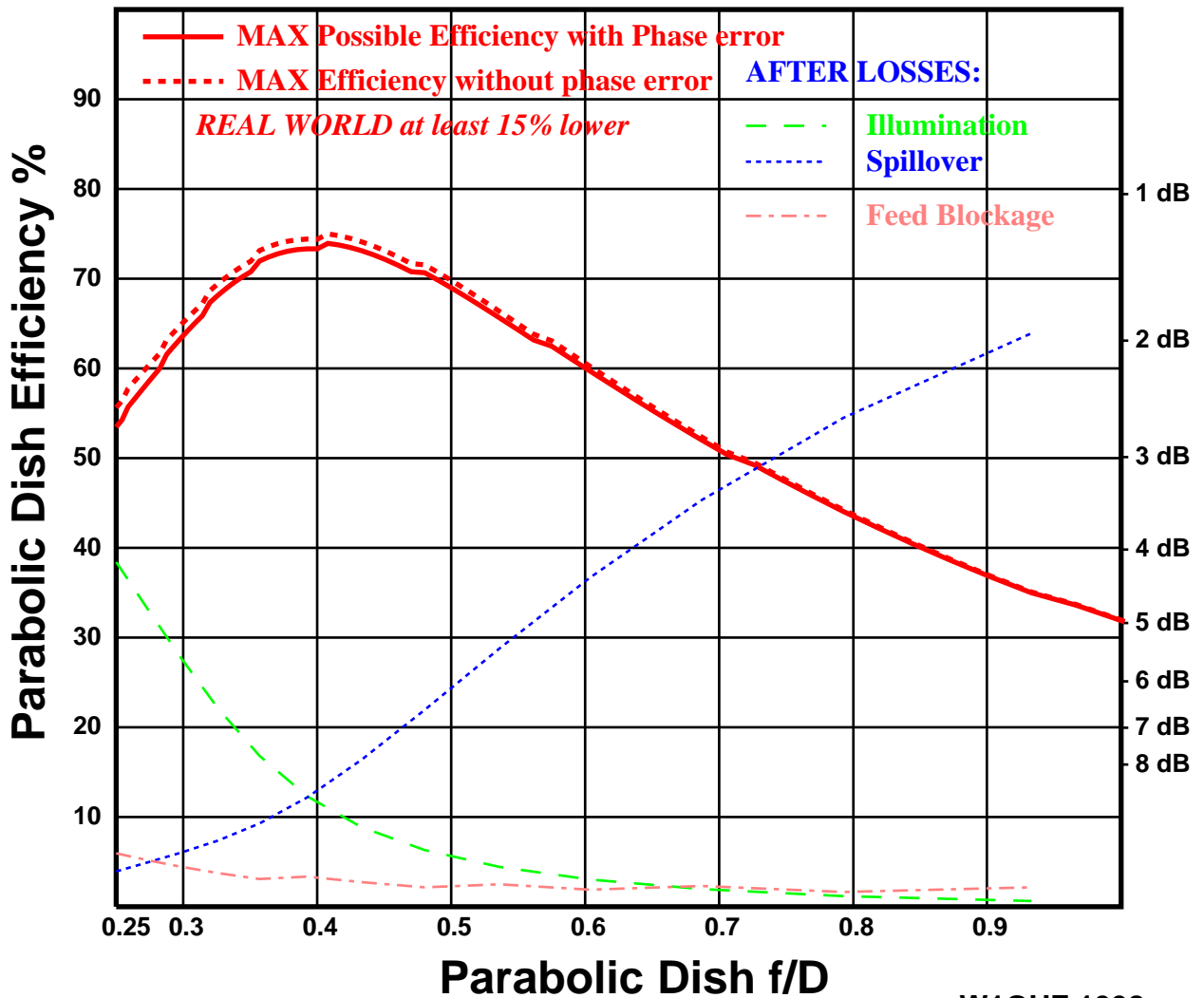

# N1BWT imitation of VE4MA feed for 5760 MHz, by NEC2

## Figure 6.3-11

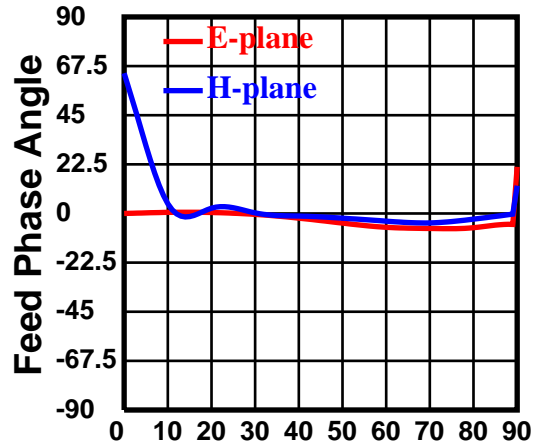
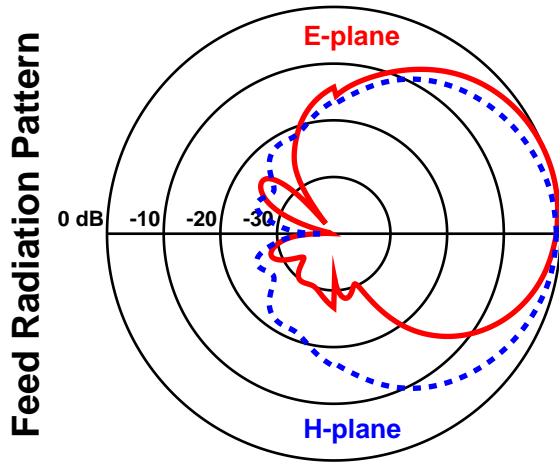

Dish diameter =  $20 \lambda$     Feed diameter =  $1.95 \lambda$

Rotation Angle around specified Phase Center =  $0 \lambda$  beyond aperture

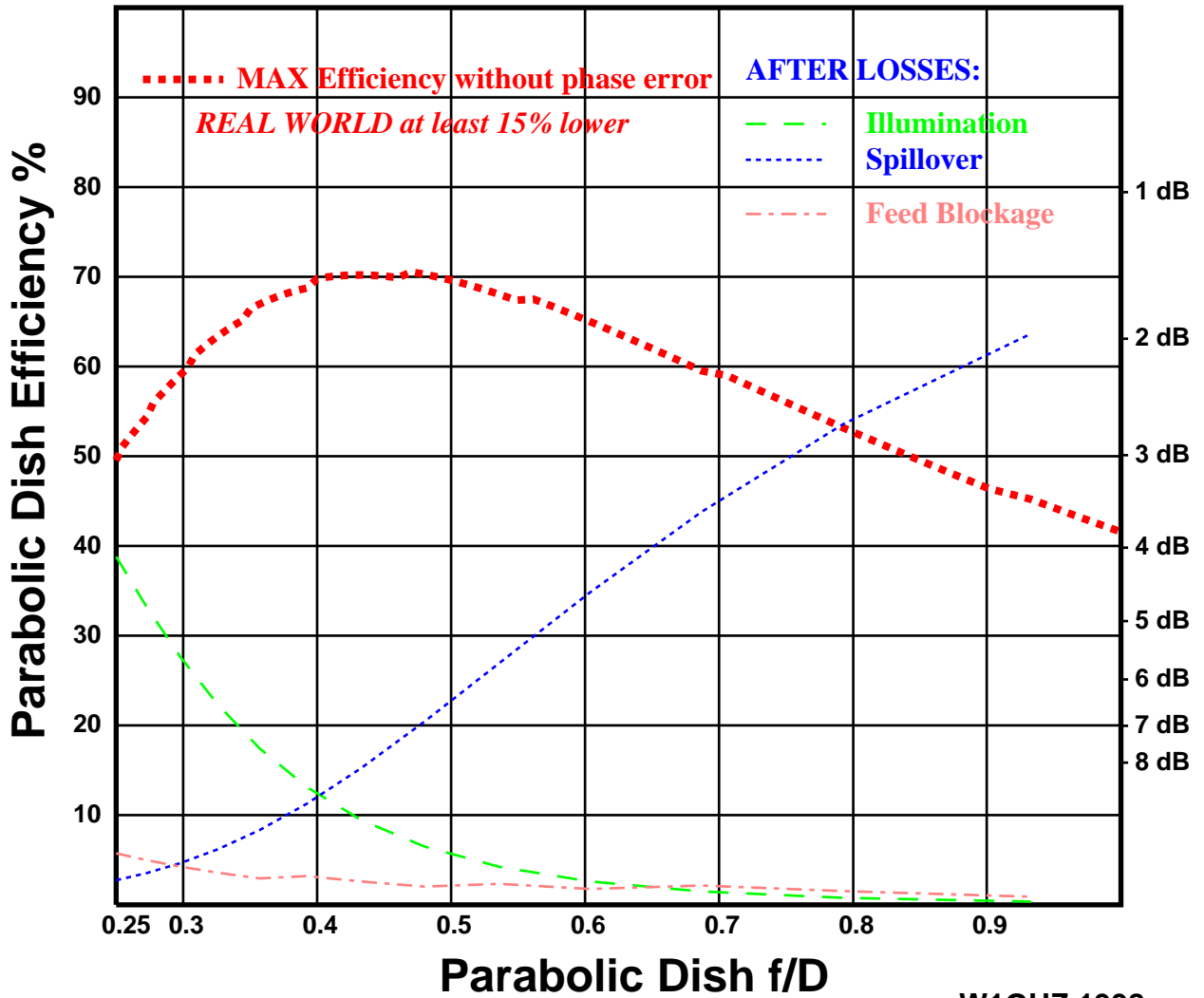

### 6.3.4 Chaparral™ feed

A further refinement to the circular horn feed is to replace the single choke ring with multiple smaller choke rings, originally described by Wohlleben<sup>15</sup>, et. al. The multiple rings, or low-Q traps, should provide additional bandwidth; ring spacing is not critical, but the depth of each ring must be greater than  $\frac{1}{4}\lambda$  to work effectively. Commercial versions of this feed are made by Chaparral™ for C- and K-band TVRO dishes, so this style of feed is commonly referred to as a Chaparral feed. Figure 6.3-12 is a photo of a Chaparral “11 GHz Superfeed” used as a 10 GHz feedhorn. The sketch with nominal dimensions<sup>5</sup> in wavelengths shown in Figure 6.3-13 has three rings; some examples have as many as four rings.



Figure 6.3-12

The radiation pattern calculated by NEC2 for a  $0.76\lambda$  diameter circular horn with three choke rings is shown in Figure 6.3-14. The calculated efficiency is very good for an  $f/D$  range around 0.35 to 0.4, suitable for most TVRO dishes. The feed in Figure 6.3-14 has the circular horn projecting  $0.26\lambda$  beyond the choke rings. At 10 GHz, we empirically found (see Chapter 9) that making the horn aperture flush with the choke rings provided more gain for a dish with  $f/D=0.45$ .

The efficiency plot in Figure 6.3-15 for the NEC2 calculated pattern in confirms this, showing higher efficiency peaking at an  $f/D$  around 0.43. The phase center in both cases is at the center of the horn aperture.

## CHAPARRAL STYLE FEED

Figure 6.3-13

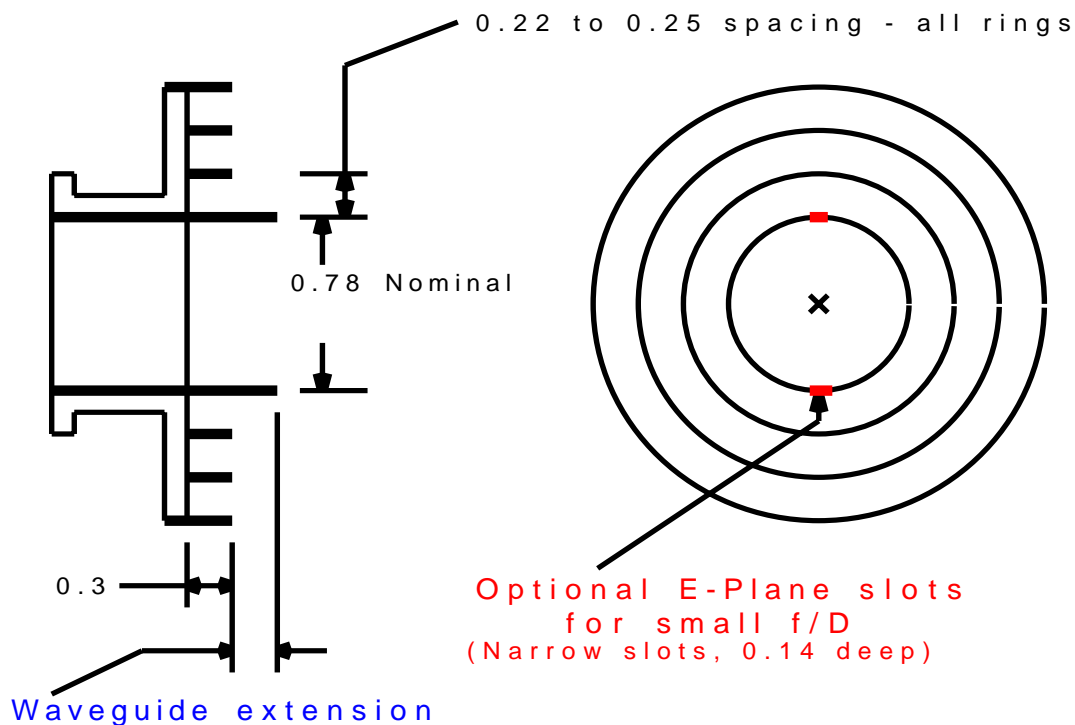

W1GHZ 1998

ALL DIMENSIONS IN WAVELENGTHS

At the suggestion of W6HD, I also calculated NEC2 radiation patterns for Chaparral-style feeds with larger and smaller circular horns. The smaller version, with a horn diameter of  $0.71\lambda$ , is best for very deep dishes. With the horn projecting  $0.1\lambda$  beyond the rings, the plots in

# Chaparral feed, $0.76\lambda$ horn dia, horn projecting $0.26\lambda$ , by NEC2

## Figure 6.3-14

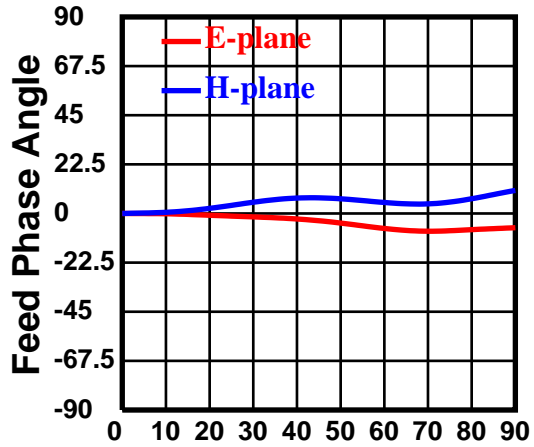
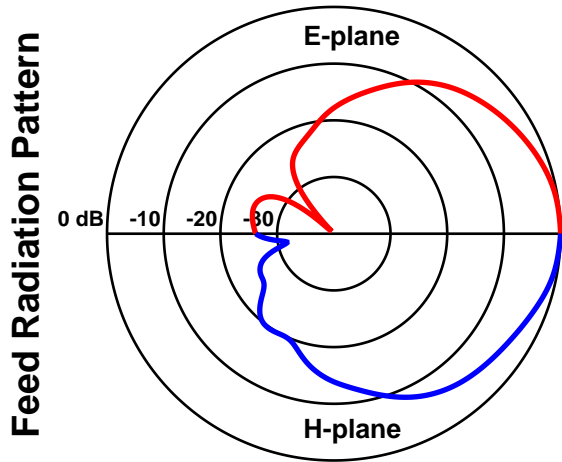

Dish diameter =  $22\lambda$     Feed diameter =  $2.2\lambda$

Rotation Angle around specified Phase Center =  $0\lambda$  beyond aperture

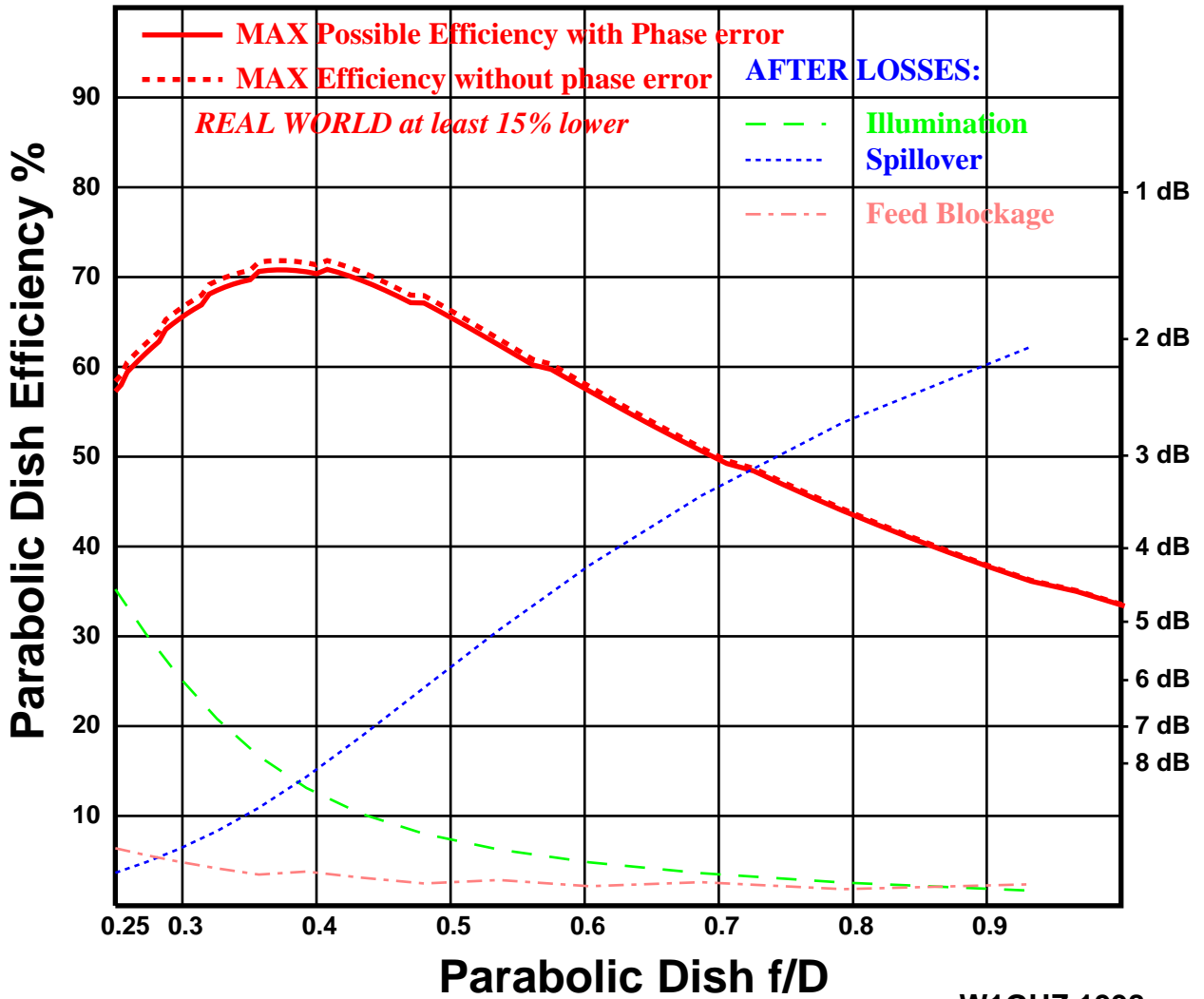



# Chaparral feed, $0.76\lambda$ horn dia, horn flush with rings, by NEC2

Figure 6.3-15

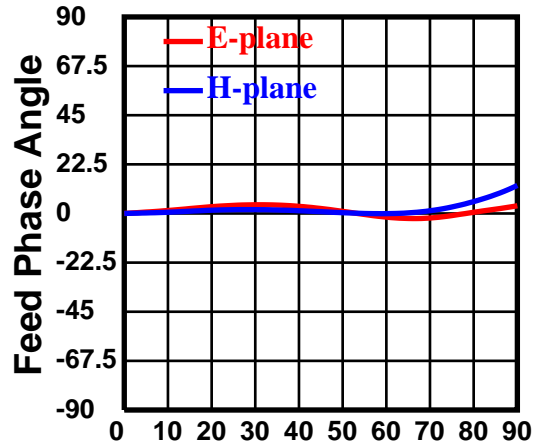
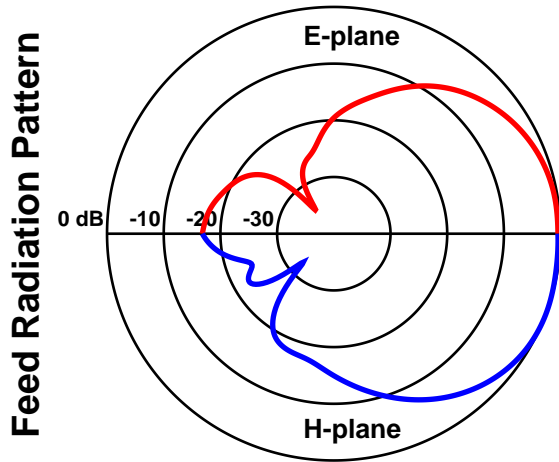

Dish diameter =  $22\lambda$  Feed diameter =  $2.2\lambda$

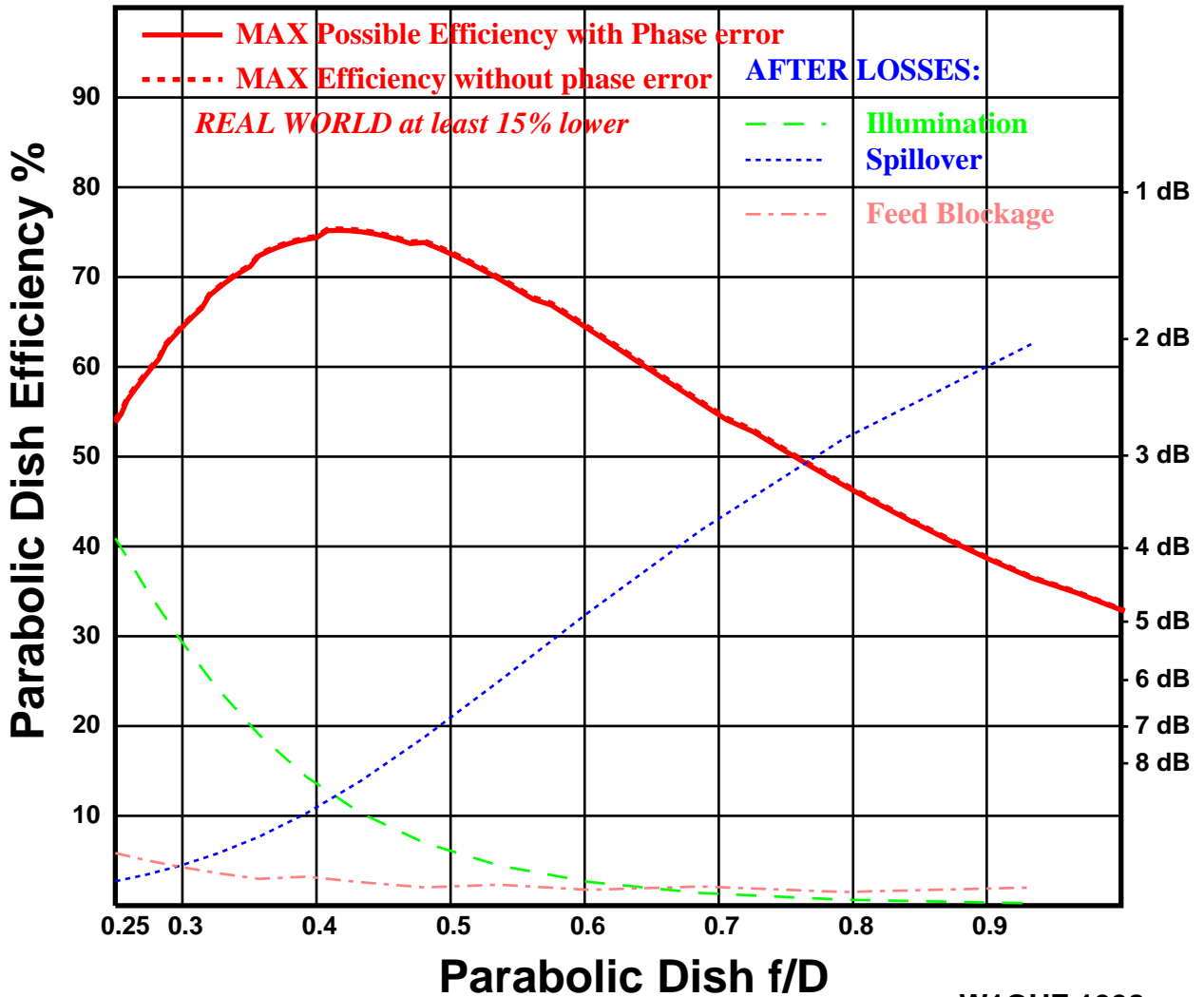

Figure 6.3-16 show very high efficiency for an  $f/D$  range around 0.3 to 0.35. The phase center is close to the center of the aperture, about  $0.08\lambda$  inside the horn, but for such a deep dish, that small difference is significant. A similar plot for the larger  $0.81\lambda$  horn diameter, Figure 6.3-17, also shows very high efficiency for an  $f/D$  range around 0.35 to 0.4, with a phase center  $0.09\lambda$  inside the aperture.

I then varied the amount of horn projection for both sizes from zero to  $0.5\lambda$  — some TVRO feeds make the choke ring location adjustable and suggest adjustment of the horn for best picture quality. The **NEC2** calculations showed that the best  $f/D$  for all horn projections was in the range of 0.33 to 0.35 for the smaller horn and 0.36 to 0.39 for the larger. The phase center moved around slightly but is always near the center of the horn aperture. Only when the horn mouth was flush with the choke rings or slightly inside them did the optimum  $f/D$  change to around 0.42.

Changing the horn diameter from  $0.71\lambda$  to  $0.81\lambda$  is equivalent to changing the frequency of operation by 13%, a bandwidth slightly wider than the 3.7 to 4.2 GHz TVRO band. Since the performance of the Chaparral-style feed shows little change over this range, we can see why it was chosen for TVRO use. The adjustable rings are probably adjusted to get the feed right at the dish focal point, since the adjustment has little affect on the radiation patterns.

By coincidence, the Chaparral™ “11 GHz Superfeed” horn diameter is  $0.71\lambda$  at 10.368 GHz, with a horn projection of  $0.19\lambda$ ; the choke rings are deep enough,  $0.28\lambda$ , to be effective. The **NEC2** calculated radiation pattern is shown in Figure 6.3-18, along with the pattern I measured<sup>16</sup> at 10.368 GHz (green dashed line). The plot shows a very high calculated efficiency, and I have measured efficiencies greater than 60% at 10 GHz on dishes larger than  $20\lambda$  in diameter. For larger dishes, feed blockage is smaller than calculated in Figure 6.3-18.

Unfortunately, the 11 GHz Chaparral feeds are no longer being manufactured; the C-band versions may be useful at 3456 MHz; check to be sure that the rings are deeper than  $\frac{1}{4}\lambda$ . Homebrewing one is fairly difficult — it took K1DPP six hours to turn a 10 GHz version on his lathe. At lower frequencies, it is possible to construct one from sheet metal, using the approximate dimensions shown in Figure 6.3-13. Clearly this feed is tolerant of small variations in dimensions, and provides excellent performance for dishes with  $f/D$  between 0.3 and 0.45. However, the VE4MA feed is probably easier to build and provides similar performance for dishes in this  $f/D$  range.

One last published variation<sup>17</sup> on the Chaparral-style feed suggests cutting small E-plane slots in the waveguide to broaden the pattern for dishes with small  $f/D$ . The slots are describe as narrow slots,  $\lambda/7$  deep, in a horn of  $0.76\lambda$  diameter. I have not made a computer model with slots, but Figure 6.3-19 is a graph of the published amplitude pattern, with best efficiency at an  $f/D$  of 0.32. The published phase data shows good phase performance to  $\pm 60^\circ$ , but with a bit of phase deviation at the  $\pm 76^\circ$  points required for the  $152^\circ$  illumination angle for this  $f/D$ . Thus the efficiency will probably decrease slightly due to phase error, but will still be very good.

# Chaparral feed, $0.71\lambda$ horn dia, horn projecting $0.1\lambda$ , by NEC2

Figure 6.3-16

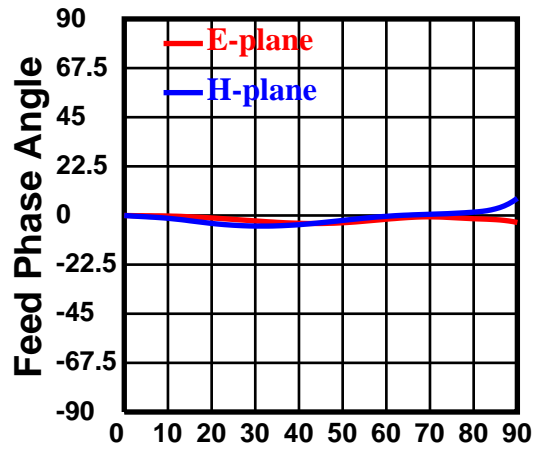
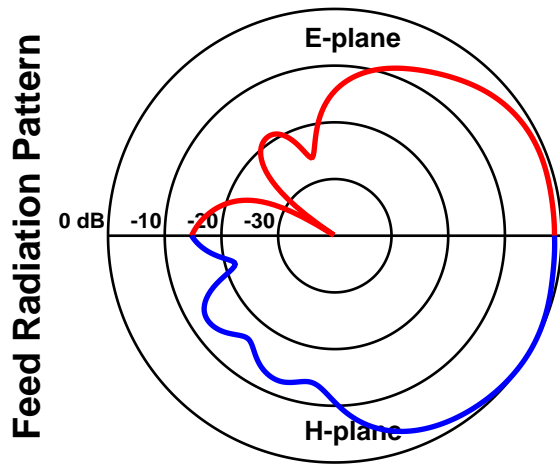

Dish diameter =  $18\lambda$  Feed diameter =  $1.8\lambda$

Rotation Angle around specified Phase Center =  $0.08\lambda$  inside aperture

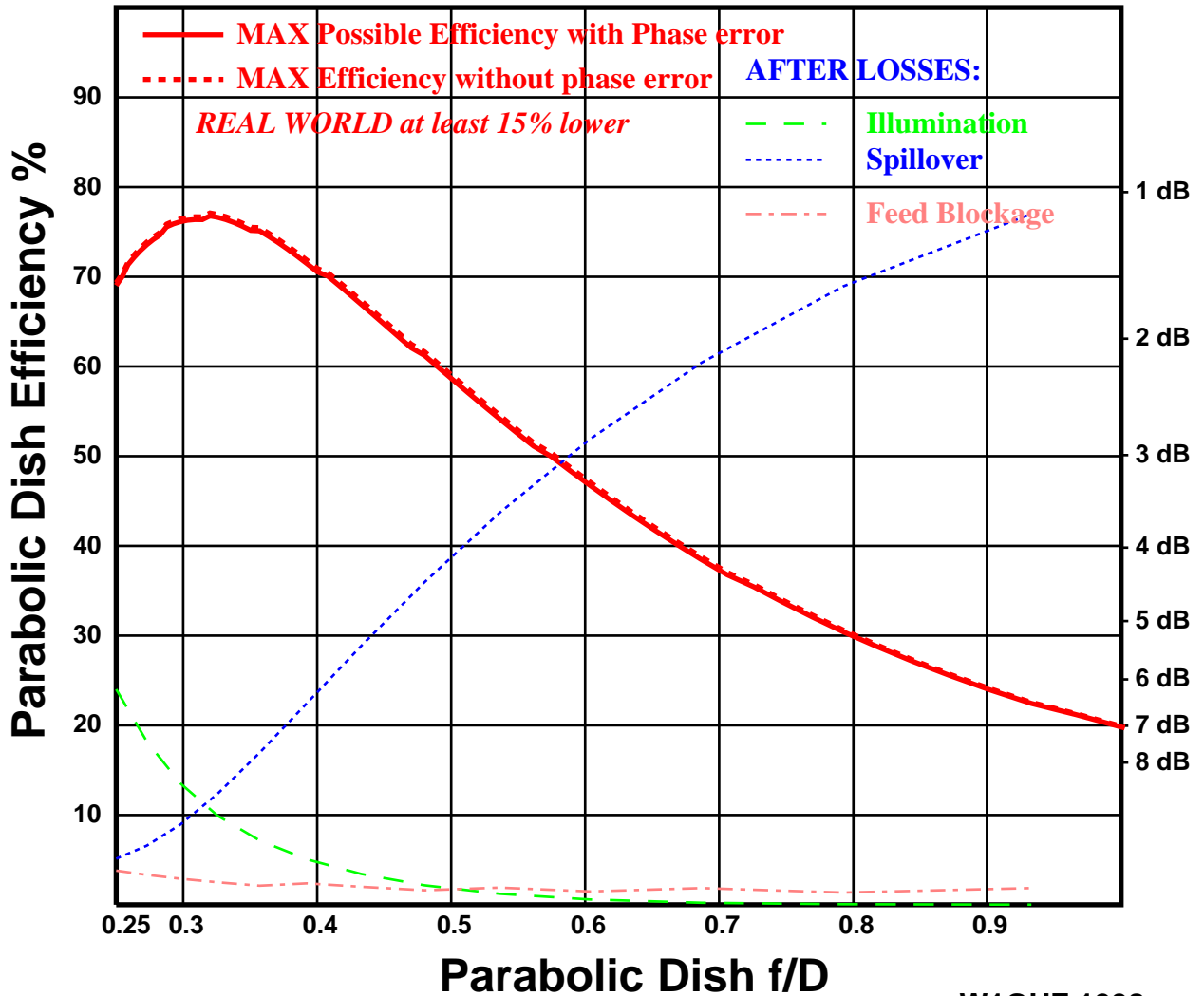

# Chaparral feed, $0.81\lambda$ horn dia, horn projecting $0.1\lambda$ , by NEC2

Figure 6.3-17

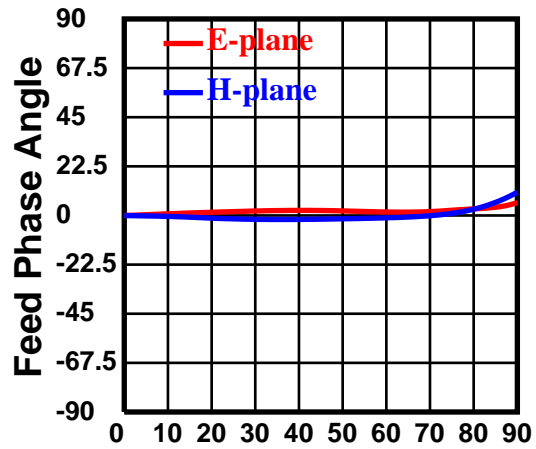
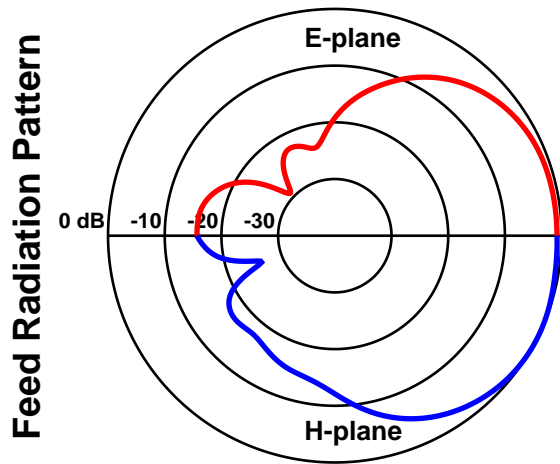

Dish diameter =  $19\lambda$  Feed diameter =  $1.9\lambda$

Rotation Angle around specified Phase Center =  $0.09\lambda$  inside aperture

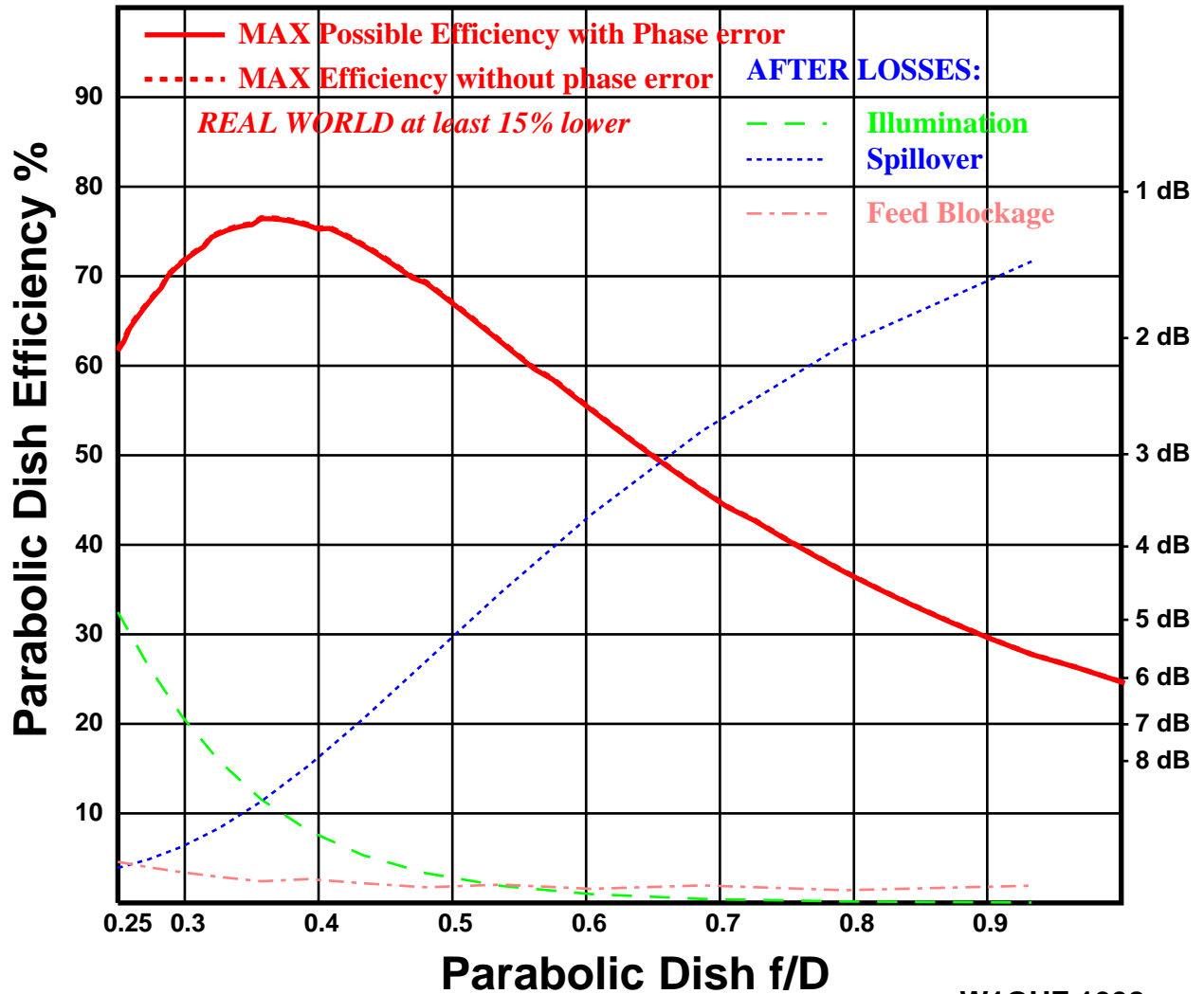

# 11 GHz Chaparral feed, $0.71\lambda$ horn dia at 10.368 GHz, by NEC2

Figure 6.3-18

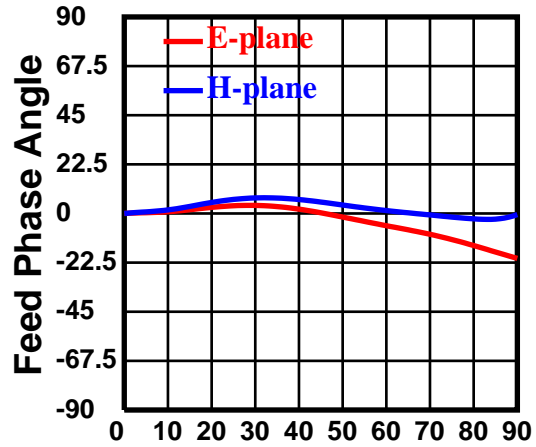
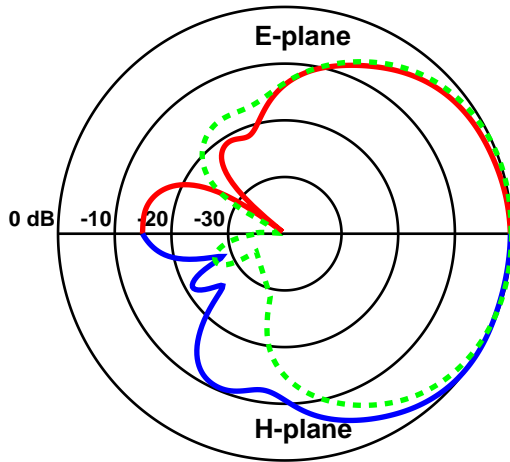

Dish diameter =  $18\lambda$  Feed diameter =  $1.8\lambda$

Rotation Angle around specified Phase Center =  $0.1\lambda$  beyond aperture

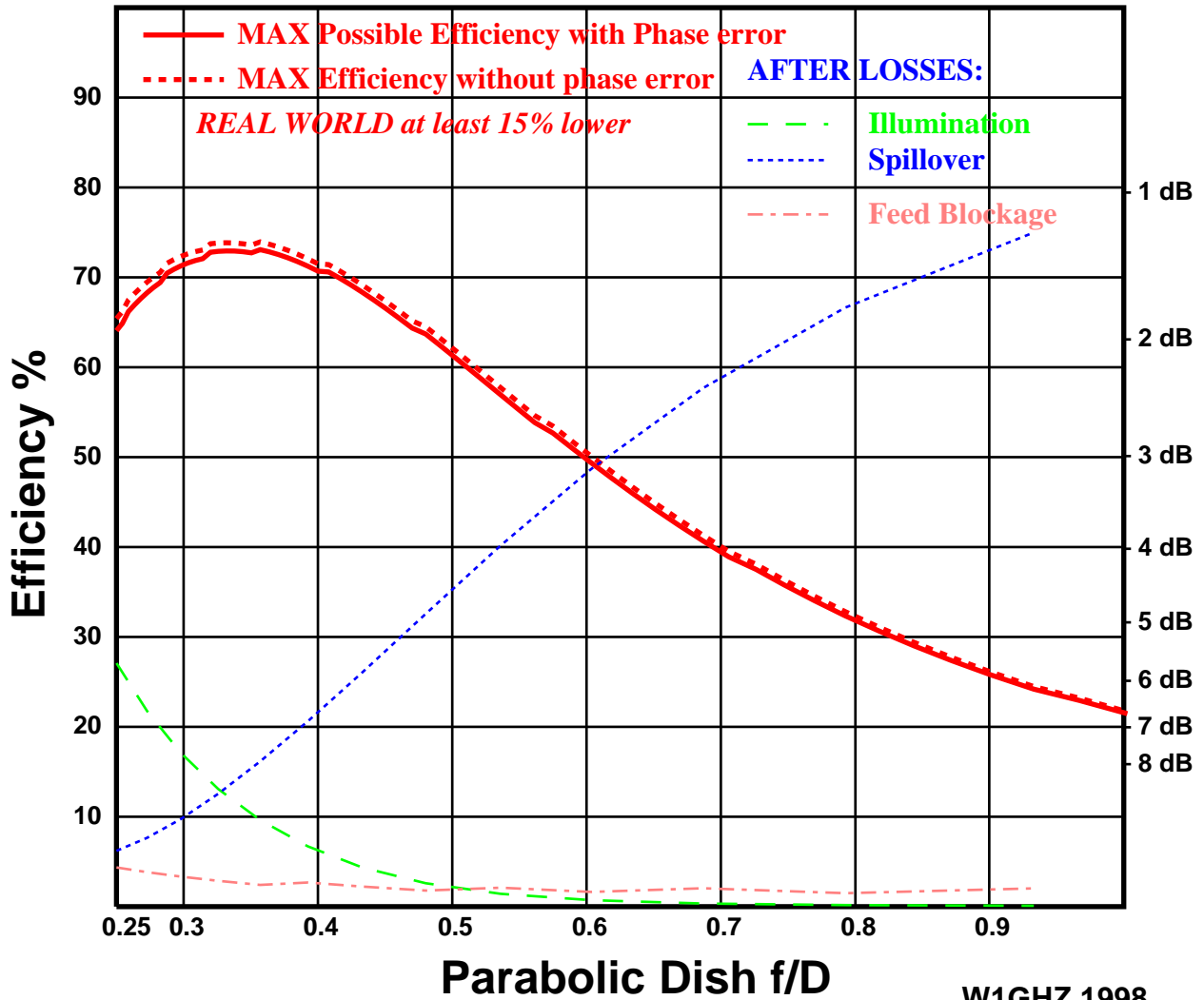

# Slotted Chaparral-style feed - horn dia = $0.76 \lambda$

## Figure 6.3-19

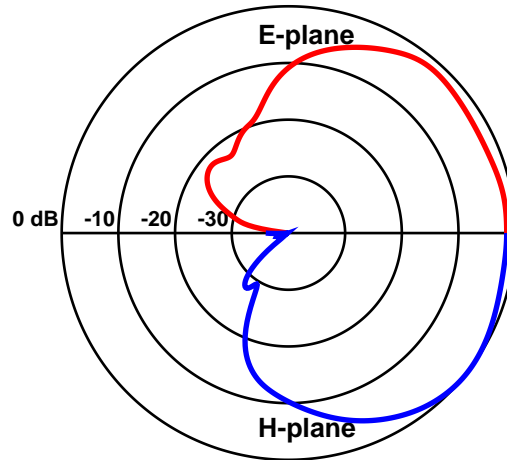

N1BWT 1997

Dish diameter =  $20 \lambda$   
 Feed diameter =  $2.1 \lambda$

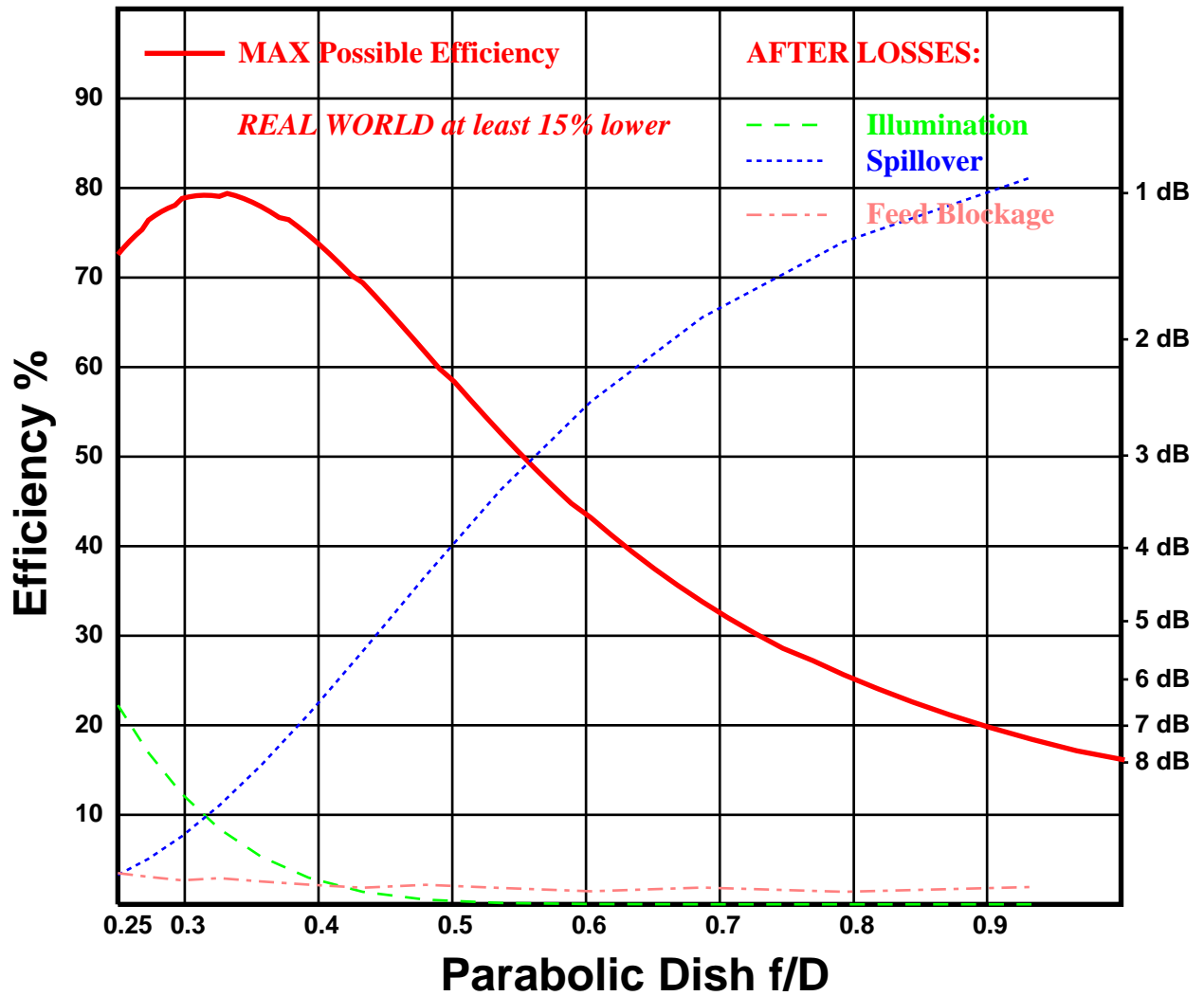

## Summary

All the feeds in this section can provide good performance for deep dishes, with  $f/D$  from 0.25 to 0.45. The VE4MA and Chaparral-style feeds offer the highest performance, while the easily constructed coffee-can feed is physically smaller and thus reduces feed blockage on small dishes. With all deep dishes, good performance is only achieved if the phase center of the feed is accurately located at the dish focus.

## 6.3 References

1. D. Vilardi, WA2VTR, "Simple and Efficient Feed for Parabolic Antennas," *QST*, March 1973, pp. 43-44.
2. J. Harrison, W5ZN, "Horns for the Holidays," *Proceedings of Microwave Update '97*, ARRL, 1997, pp. 147-149.
3. B.W. Malowanchuk, VE4MA, "Use of Small TVRO Dishes for EME," *Proceedings of the 21st Conference of the Central States VHF Society*, ARRL, 1987, pp. 68-77.
4. H. Jasik, *Antenna Engineering Handbook*, First Edition, McGraw-Hill, 1961. Fig. 10-15, p. 10-16.
5. D. Turrin, W2IMU, "Parabolic Reflector Antennas and Feeds," *The ARRL UHF/Microwave Experimenter's Manual*, ARRL, 1990, p. 9-30.
6. N.J. Foot, WA9HUV, "second-generation cylindrical feedhorns," *ham radio*, May 1982, pp. 31-35.
7. N.J. Foot, WA9HUV, "cylindrical feedhorns revisited," *ham radio*, Feb. 1986, pp. 20-22.
8. A. Kumar, "Reduce Cross-Polarization in Reflector-Type Antennas," *Microwaves*, March 1978, pp. 48-51.
9. B.W. Malowanchuk, VE4MA, "Selection of an Optimum Dish Feed," *Proceedings of the 23rd Conference of the Central States VHF Society*, ARRL, 1989, pp. 35-43.
10. B.W. Malowanchuk, VE4MA, "VE4MA 3456 MHz circular polarization feed horn," *North Texas Microwave Society Feedpoint*, Nov/Dec 1991.
11. B.W. Malowanchuk, VE4MA, "VE4MA 5760 MHz Linear Polarization Feedhorn," *Proceedings of Microwave Update '95*, ARRL, 1995, p. 214.
12. A. Ward, WB5LUA, "5760 MHz WR-137 Feedhorn," *Proceedings of Microwave Update '95*, ARRL, 1995, p. 215.
13. B.W. Malowanchuk, VE4MA, "VE4MA 10 GHz Copper Water Pipe Feedhorn," *Proceedings of Microwave Update '97*, ARRL, 1997, p. 288.
14. P.C. Wade, N1BWT, "High-Performance Antennas for 5760 MHz," *QEX*, January 1995, pp. 18-21.
15. R. Wohlleben, H. Mattes, O. Lochner, "Simple small primary feed for large opening angles and high aperture efficiency," *Electronics Letters*, 21 Sept. 1972, pp. 181-183. (reprinted in A.W. Love, *Electromagnetic Horn Antennas*, IEEE, 1976, pp. 181-183.)
16. P.Wade, N1BWT, "Parabolic Dish Feeds — Performance Analysis," *QEX*, January/February 1998, pp. 9-33.
17. L. Shafai, "Broadening of primary feed patterns by small E-plane slots," *Electronic Letters*, 17th February 1977, pp. 102-103.