

# STANDARD MICROPHONE PREAMP INPUT CIRCUITRY

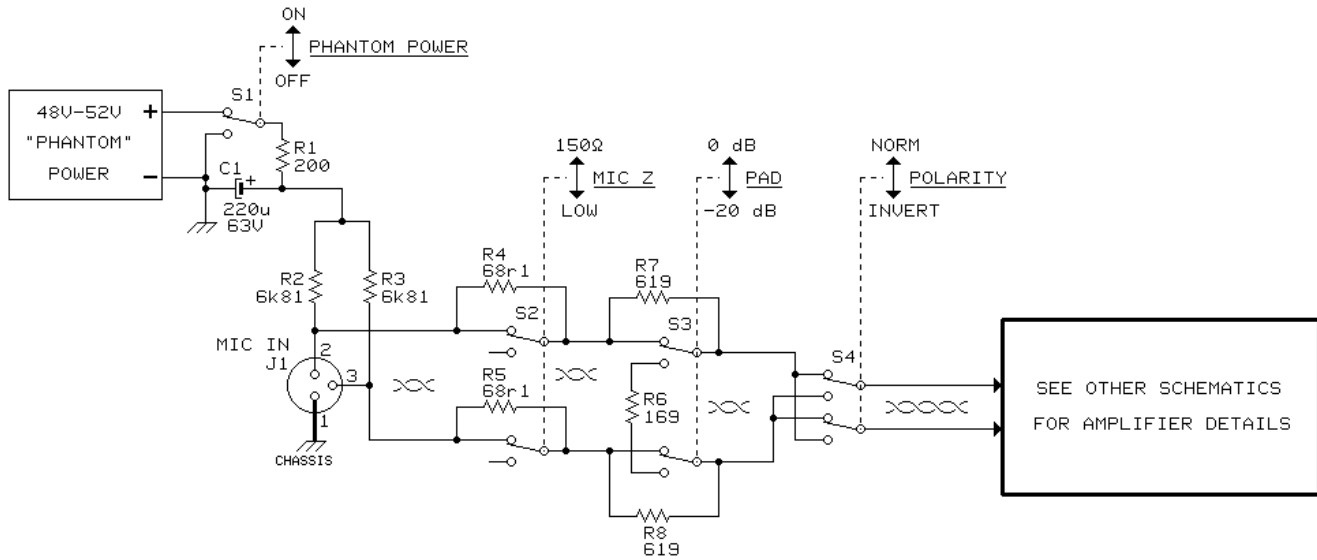

## NOTES

- ALL RESISTORS ARE  $\pm 1\%$  1/4w METAL FILM TYPES, ROEDERSTEIN MK2-1 OR EQUIVALENT
- TIGHTLY TWIST LEADS AS SHOWN  $\times\times$  IN PATH FROM J1 TO INPUT TRANSFORMER TO MINIMIZE ELECTROMAGNETIC PICKUP
- RESISTORS R2 AND R3 SHOULD BE MATCHED TO  $\pm 0.1\%$  FOR BEST COMMON MODE NOISE REJECTION
- USE ONLY QUALITY SWITCHES WITH GOLD PLATED "VIRGIN" CONTACTS AT S2, S3, AND S4
- USE OF GOLD PLATED CONTACTS IN XLR CONNECTOR AT J1 IS HIGHLY RECOMMENDED
- ALL RESISTORS IN OHMS ( 6k81 = 6.81k, 68r1 = 68.1 )
- MAKE THE J1, PIN 1 CONNECTION TO CHASSIS AS SHORT AND DIRECT AS POSSIBLE.

<b>jensen</b>	AS016
	09/20/94
7135 HAYVENHURST AVE. VAN NUYS, CALIFORNIA 91406 (818) 374-5857	